

# MULTIPROP MP 120, 250, 350, 480, 625 Slab Props

Instructions for Assembly and Use – Standard Configuration - 06/2019

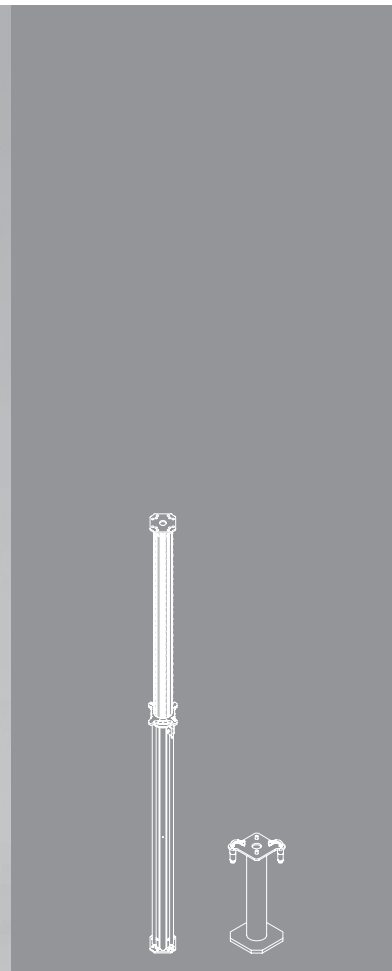

## Main Components

### MULTIPROP MP

- 1 Outer Tube
- 2 Inner Tube
- 3 Safety Hook
- 4 Adjusting Collar
- 5 Pressure Spring
- 6 Measuring Scale
- 7 Rubbing Plate
- 8 End Plate

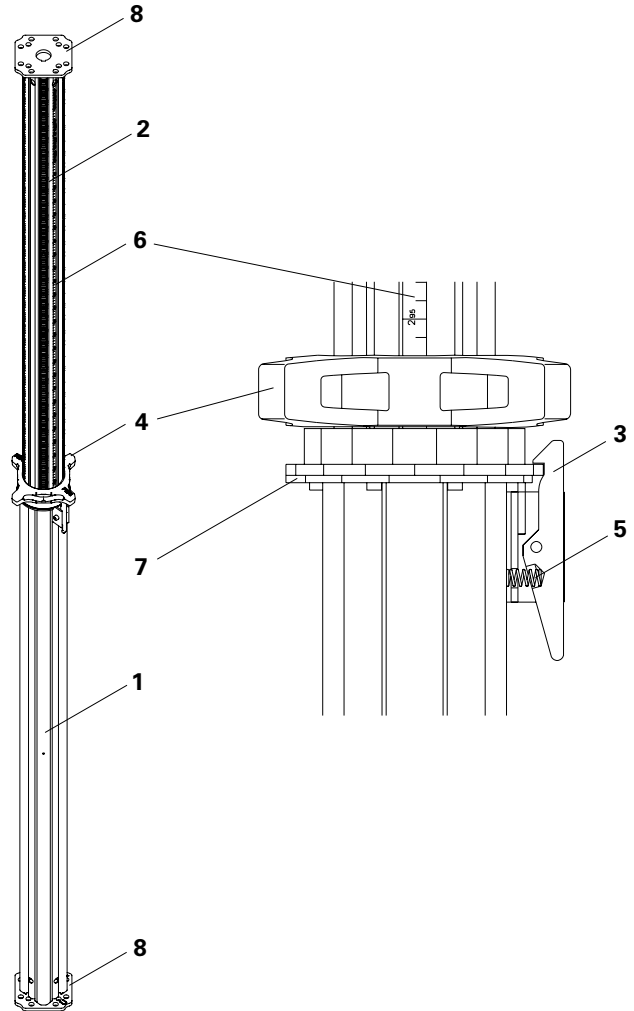

### Base MP 50

- 11 Base MP 50
- 11a Head Plate
- 11c Clamping Claw
- 11b Centering Pin

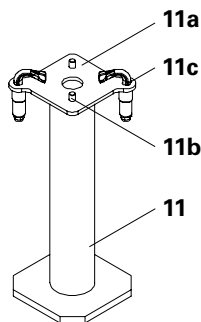

<b>Overview</b>	
Main Components	3
Key	4
<b>Introduction</b>	
Target Groups	5
Additional Technical Documentation	5
Intended Use	6
Instructions on Use	6
Cleaning and Maintenance Instructions	7
<b>Safety Instructions</b>	
Cross-System	8
System-Specific	9
Care and Maintenance	9
<b>Standard Configuration</b>	
A1 Assembly	
Pre-assembling the Slab Prop	10
Assembly with the Universal Tripod	12
A2 Dismantling	
Releasing the Slab Prop under load	13
A3 Accessories	
Brace Clamp	14
Base MP 50	15
A4 Foreseeable Misapplications	
Non-use of damaged parts	16
Ensuring Slab Props are in a perpendicular position	17
Using only full-faced support surfaces	17
Non-loadable installation surface	17
Not connecting several Slab Props to each other	18
Do not use with Tilting Forkhead MKK or Tilting Base MKF	18
Do not use to support formwork elements	18
Do not use as a trench strut	19
Do not use as anti-fall protection	19
Do not use as a Guardrail Holder	19
A5 Storage and Transportation	20
<b>Tables: permissible prop loads</b>	
MULTIPROP 120, 250, 350	22
MULTIPROP 480, 625	23
MULTIPROP 120, 250, 350 with Base MP 50	24
MULTIPROP 480, 625 with Base MP 50	25
<b>Components</b>	
MULTIPROP Slab Props	26

## Key

### Pictogram | Definition

 Danger / Warning / Caution

 Information

 To be complied with

 Load-bearing point

 Visual check

 Tip

 Misapplication

 Safety helmet

 Safety shoes

 Safety gloves

 Safety glasses

 Personal protective equipment to prevent falling from a height (PPE)

### Arrows

 Arrow representing an action

 Arrow representing a reaction of an action\*

 Forces

\* If not identical to the action arrow.

### Safety instruction categories

The safety instructions alert site personnel to the risks involved and provide information on how to avoid these risks. Safety instructions are featured at the beginning of the section or ahead of the instructions, and are highlighted as follows:

#### **Danger**

This sign indicates an extremely hazardous situation which, if not avoided, will result in death or serious injury.

#### **Warning**

This sign indicates a hazardous situation which, if not avoided, could result in death or serious injury.

#### **Caution**

This sign indicates a hazardous situation which, if not avoided, could result in minor or moderate injury.

#### **Information**

This sign indicates situations in which failure to observe the information can result in material damage.

### Set-up of the safety instructions

#### **Signal word**

Type and source of the danger!  
Consequences of non-compliance.  
⇒ Avoidance measures.

### Dimension specifications

Dimensions are usually given in cm. Other measurement units, e.g. m, are shown in the illustrations.

### Conventions

- Instructions are numbered with: 1. ...., 2. ...., 3. ....
- The result of an instruction is shown by:
- Position numbers are clearly provided for the individual components and are given in the drawing, e.g. **1**, in the text in brackets, for example **(1)**.
- Multiple position numbers, i.e. alternative components, are represented with a slash: e.g. **1 / 2**.

### Presentational reference

The illustration on the front cover of these instructions is understood to be a system representation only. The assembly steps presented in these Instructions for Assembly and Use are shown in the form of examples with only one component size. They are valid accordingly for all component sizes contained in the standard configuration.

For a better understanding, detailed illustrations are partly incomplete. Some safety installations which have possibly not been shown in these detailed descriptions must nevertheless still be available.

## Target Groups

### Contractors

These Instructions for Assembly and Use are designed for contractors who use the scaffolding either for

- assembling, modifying and dismantling operations, or
- use it, e.g. for concreting, or
- who have it used, e.g. for forming operations.

### Competent person

(Construction Site Coordinator)  
The Safety and Health Protection Coordinator\*

- is appointed by the client,
- must identify potential hazards during the planning phase,
- determines measures that provide protection against risks,
- creates a health and safety plan,
- coordinates the protective measures for the contractor and site personnel so that they do not endanger each other,
- monitors compliance with the protective measures.

### Competent person qualified to carry out inspections

Due to the specialist knowledge gained from professional training, work experience and recent professional activity, the competent person qualified to carry out inspections has a reliable understanding of safety-related issues and can carry out inspections correctly. Depending on the complexity of the test to be undertaken, e.g. scope of testing, type of testing or the use of certain measuring devices, a range of specialist knowledge is necessary.

### Qualified personnel

The scaffolding may only be assembled, modified or dismantled by personnel who are suitably qualified to do so. For the work to be carried out, the qualified personnel must have received instructions\*\* covering at least the following points:

- An explanation of the plan for the assembly, modification or dismantling of the scaffolding in an understandable form and language.
- Description of the measures for

safely assembling, modifying or dismantling the scaffolding.

- Naming of the preventive measures to be taken to avoid the risk of persons and objects falling.
- Designation of the safety precautions in the event of changing weather conditions that could adversely affect the safety of the scaffolding, as well as the personnel concerned.
- Details regarding permissible loads.
- Description of all other risks and dangers associated with assembly, modification or dismantling operations.



- **In other countries, ensure that the relevant national guidelines and regulations in the respective current version are complied with!**
- **If no country-specific regulations are available, it is recommended to proceed according to German guidelines and regulations.**
- **A competent person must be present on site during scaffolding operations.**

\* Valid in Germany: Regulations for Occupational Health and Safety on Construction Sites 30 (RAB 30)

\*\* Instructions are given by the contractor himself or a competent person selected by him.

## Additional Technical Documentation

- Brochure:
  - MULTIPROP Aluminium Slab Props
- Type tests for:
  - MULTIPROP Props
  - MULTIPROP System
  - MULTIPROP Props with Base MP 50
  - MULTIPROP System with Base MP 50
- Instructions for Use:
  - Pallets and Stacking Devices
- Instructions for Assembly and Use
  - MULTIFLEX
  - SKYDECK
  - TABLE MODULES / SLAB TABLES
  - SKYTABLE
  - VARIODECK
- PERI Design Tables - Formwork and Shoring

**The structures shown in these Instructions for Assembly and Use are examples and feature only one prop type and component size respectively. They are valid accordingly for all types and component sizes contained in the standard configuration.**

## Intended Use

### Product description

MULTIPROP Slab Props

- are props made of aluminium
- correspond to the load requirements of DIN EN 16301,
- are used as vertical supports for temporary constructions.

### Features

MULTIPROP Slab Props are used in shoring operations in a planned perpendicular position for the transfer of vertical loads. In particular, they also provide support for slab formwork systems.

The outer tubes of the MULTIPROP Slab Props are powder coated.

The integrated measuring scale and free-running collar allow accurate and fast height adjustment.

The height is continuously adjustable by means of the end-to-end thread without any pegging.

The MULTIPROP Slab Prop has a fail-safe feature which prevents the inner tube from unintentionally slipping out.

### Main Components

MULTIPROP

- MP 120, L = 0.80 – 1.20 m
- MP 250, L = 1.45 – 2.50 m
- MP 350, L = 1.95 – 3.50 m
- MP 480, L = 2.60 - 4.80 m
- MP 625, L = 4.30 – 6.25 m

### System dimensions

Assembly heights as individual props according to the permissible extension lengths 0.80 m - 6.25 m or 1.30 m - 6.75 m for use with Base MP 50.

### Technical data

- Approval Z-8.312-824
- Type Test S-N/160206
- For load-bearing capacities, see Tables

---

## Instructions on Use

Use in a way not intended according to the Instructions for Assembly and Use, or any use deviating from the standard configuration or the intended use, represents a misapplication with a potential safety risk, e.g. risk of falling.

Deviations from the standard configuration must be verified for the application by means of separate strength and stability calculations (Industrial Safety Regulation Appendix 1, No. 3.2.1) and explicitly reflected in the assembly instructions.

Only PERI original parts may be used.

The use of other products and spare parts is not allowed.

Changes to PERI components are not permitted.

The system described in these Instructions for Assembly and Use may contain patent-protected components.

## Cleaning and Maintenance Instructions

Lubricate the Rubbing Plate on a regular basis in order to facilitate easier release of the Quick Jack Nut when under load.

Clean the panels after each use to maintain the value and usability of the PERI products over the long term.

Some repair work may also be inevitable due to the tough working conditions. The following points should help to keep cleaning and maintenance costs as low as possible.

Never clean powder-coated components, e.g. elements and accessories, with a steel brush or hard metal scraper: this ensures that the powder coating remains intact.

Provide suitable support for the components during cleaning so that no unintentional change in their position is possible.

Do not clean components suspended on crane lifting gear.

Any repairs to PERI products are to be carried out by PERI qualified personnel only.

## Cross-System

### General

The contractor must ensure that the Instructions for Assembly and Use supplied by PERI are available at all times and understood by the site personnel.

These Instructions for Assembly and Use can be used as the basis for creating a risk assessment. The risk assessment is compiled by the contractor. However, these Instructions for Assembly and Use do not replace the risk assessment!

Always take into consideration and comply with the safety instructions and permissible loads.

For the application and inspection of PERI products, the current safety regulations and guidelines valid in the respective countries must be observed.

Materials and working areas are to be inspected on a regular basis, especially before each use and assembly, for:

- signs of damage,
- stability and
- function.

Damaged components must be exchanged immediately on site and may no longer be used.

Safety components are to be removed only when they are no longer required.

Components provided by the contractor must conform to the characteristics required in these Instructions for Assembly and Use, as well as all valid construction guidelines and standards. Unless otherwise indicated, this applies in particular to:

- timber components: Strength Class C24 for Solid Wood according to EN 338.
- scaffold tubes: galvanised steel tubes with minimum dimensions of  $\varnothing 48.3 \times 3.2$  mm according to EN 12811-1:2003 4.2.1.2.
- scaffold tube couplers according to EN 74.

Deviations from the standard configuration are only permitted after a further risk assessment has been carried out by the contractor.

Appropriate measures for working and operational safety, as well as stability, are defined on the basis of this risk assessment.

Corresponding proof of stability can be provided by PERI on request if the risk assessment and resulting measures to be implemented are made available.

Before and after exceptional occurrences that may have an adverse effect on the safety of the scaffolding system, the contractor must immediately

- create an additional risk assessment, with appropriate measures for ensuring the stability of the formwork system being carried out based on the results,
- arrange for an extraordinary inspection to be carried out by a competent person qualified to do so. The aim of this inspection is to identify and rectify any damage in good time, in order to guarantee the safe use of the scaffolding system.

Exceptional occurrences can include:

- accidents,
- longer periods of non-use,
- natural events, e.g. heavy rainfall, icing, heavy snowfall, storms or earthquakes.

### Assembly, modification and dismantling work

Assembly, modification or dismantling of the shoring system may only be carried out by qualified persons and under the supervision of a competent person. The qualified personnel must have received appropriate training for the work to be carried out with regard to specific risks and dangers.

On the basis of the risk assessment and Instructions for Assembly and Use, the contractor must create assembly instructions in order to ensure safe assembly, modification and dismantling of the shoring system.

Before initial use, the safe functioning of the shoring system must be checked by a person qualified to carry out the inspection. The results of the inspection must be documented in an inspection record.

The contractor must ensure that the personal protective equipment required for the assembly, modification or dismantling of the shoring system, e.g.

- safety helmet,
- safety shoes,
- safety gloves,
- safety glasses,

is available and used as intended.

If personal protective equipment against falling from a height (PPE) is required or specified in local regulations, the contractor must determine appropriate attachment points on the basis of the risk assessment.

The contractor stipulates the PPE to be used to prevent falling.

The contractor must

- provide safe working areas for site personnel, which are to be reached through the provision of safe access ways. Areas of risk must be cordoned off and clearly marked.
- ensure stability during all stages of construction, in particular during assembly, modification and dismantling operations.
- ensure and prove that all loads can be safely transferred.

### Utilisation

Every contractor who uses or allows the scaffolding system or sections of the scaffolding system to be used, is responsible for ensuring that the equipment is in good condition.

If the scaffolding system is used successively or at the same time by several contractors, the health and safety coordinator must point out any possible mutual hazards, and all work must then be coordinated.



## System-Specific

Retract components only when the concrete has sufficiently hardened and the person in charge has given the go-ahead for striking to take place.

Anchoring is to take place only if the anchorage has sufficient concrete strength.

After exceptional occurrences or long periods of downtime at the location where the formwork or shoring is used, the unit and its components must be checked for stability and functionality.

## Pre-assembling the Slab Prop



- For the safety of the user, the following should be checked before every use to make sure
  - the Slab Prop is complete,
  - the Slab Prop has no cracks, holes or broken parts,
  - the Inner Tube and Collar are freely movable and
  - the End Plates are level.
- Shown here is the assembly of a free-standing MULTIPROP Slab Prop.
- When used in the system, the “MULTIPROP System” Instructions for Assembly and Use must be adhered to.
- The numbers on the integrated measuring tape show the complete length (**L**) of the MULTIPROP Slab Prop in metres [m], e.g. 125 = 1.25 m.
- The complete length of the MULTIPROP Slab Prop can be read at the top edge of the Collar (**4a**).
- Adjusting range per complete turn: 36 mm.
- The Prop can be continuously readjusted by means of the Adjusting Collar if partially loaded up to 15 kN.

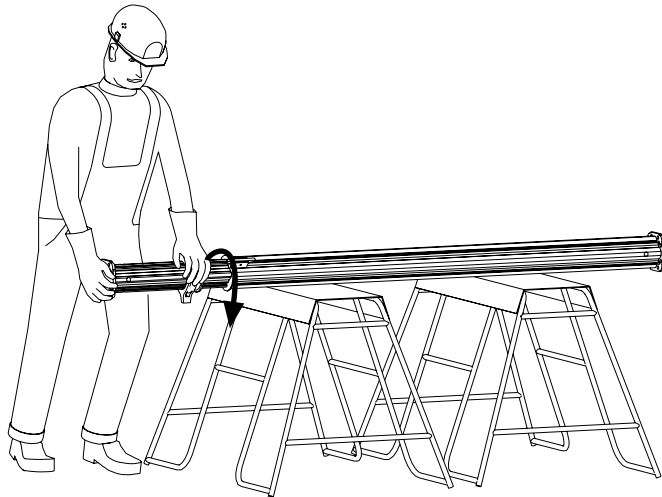

Fig. A1.01a

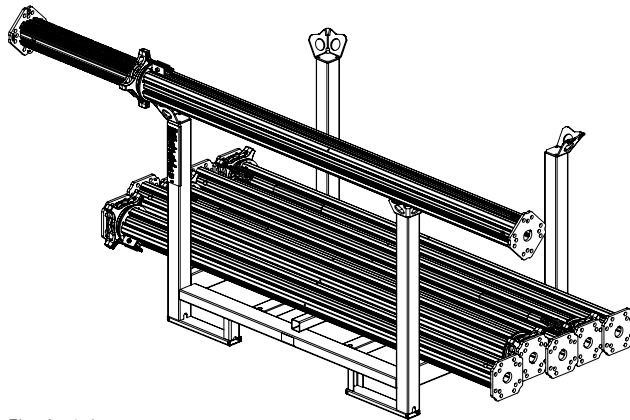

Fig. A1.01b

### Preparation

MULTIPROP Slab Props are delivered with retracted Inner Tubes in a RP-2 Pallet as standard.

Place the Slab Prop on an available work trestle or the Pallet RP-2.

(Fig. A1.01a + A1.01b)

## Turning direction of the Adjusting Collar

Position	Turn the Adjusting Collar	"L" is:
Outer Tube bottom (Fig. A1.02b)	anti-clockwise	smaller
	clockwise	larger
Inner Tube bottom (Fig. A1.02c)	anti-clockwise	larger
	clockwise	smaller

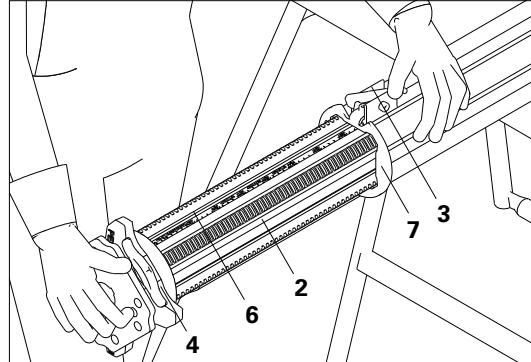

Fig. A1.02a

## Rough adjustment of the extension length

1. Press down the Safety Hook (3).  
→ Inner Tube (2) together with the Adjusting Collar is released.  
(Fig. A1.02a)
2. Pull out the Inner Tube until the length indicated on the measuring tape (6) is slightly more than the required prop length.
3. Turn the Adjusting Collar until the required extension length is reached.
4. Push in the Inner Tube until the Adjusting Collar lies against the rubbing plate (7).  
→ Safety Hook locks the Inner Tube in position.
5. Fine adjustment of the Adjusting Collar (4) to the specified length.



Is the Safety Hook engaged?



- The tip of the arrow on the Quick Jack Nut indicates the direction for releasing.
- Quick adjustment of the smooth-running Adjusting Collar is carried out by "fast spindling".

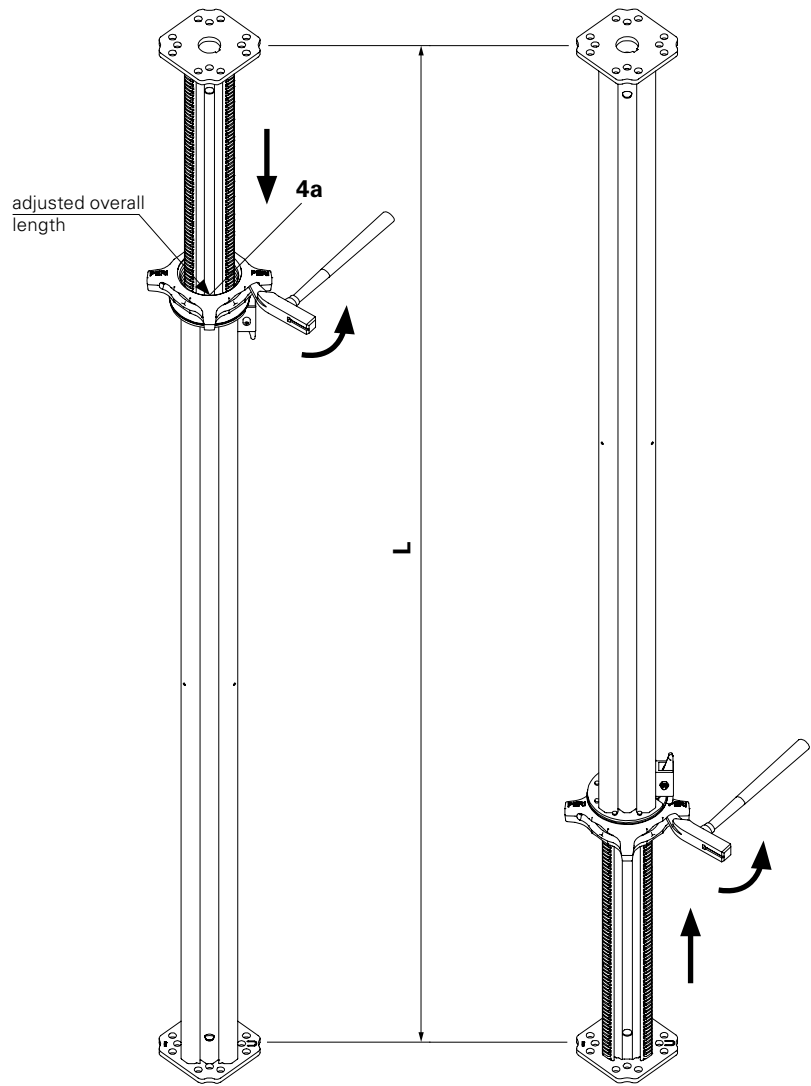

Outer Tube bottom  
Fig. A1.02b

Inner Tube bottom  
Fig. A1.02c

## Assembly with the Universal Tripod

For Slab Props with Tube  $\varnothing$  48 mm to  $\varnothing$  120 mm



- Universal Tripods (9) are simply assembly aids for shuttering and striking up to heights of approx. 3 m.
- The Slab Prop and Tripod are not suitable for a planned transfer of horizontal loads!
- Place the Slab Prop and Tripod on a clean, flat and sufficiently load-bearing surface only!
- When used in the system, the respective Instructions for Assembly and Use are to be taken into account.
- Shown here is the assembly of a free-standing Slab Prop.

### Universal Tripod assembly

1. Insert the pre-assembled Slab Prop in the Universal Tripod (9).
  2. Tighten clamp (9a).  
Ensure that the Slab Prop lies flat against the top and bottom Connection Plates (9b + 9c).
- (Fig. A1.03)



Does the Slab Prop lie completely flat against the top and bottom Connection Plates?

- Has the clamp been tightened?
- Is the Slab Prop in a perpendicular position?

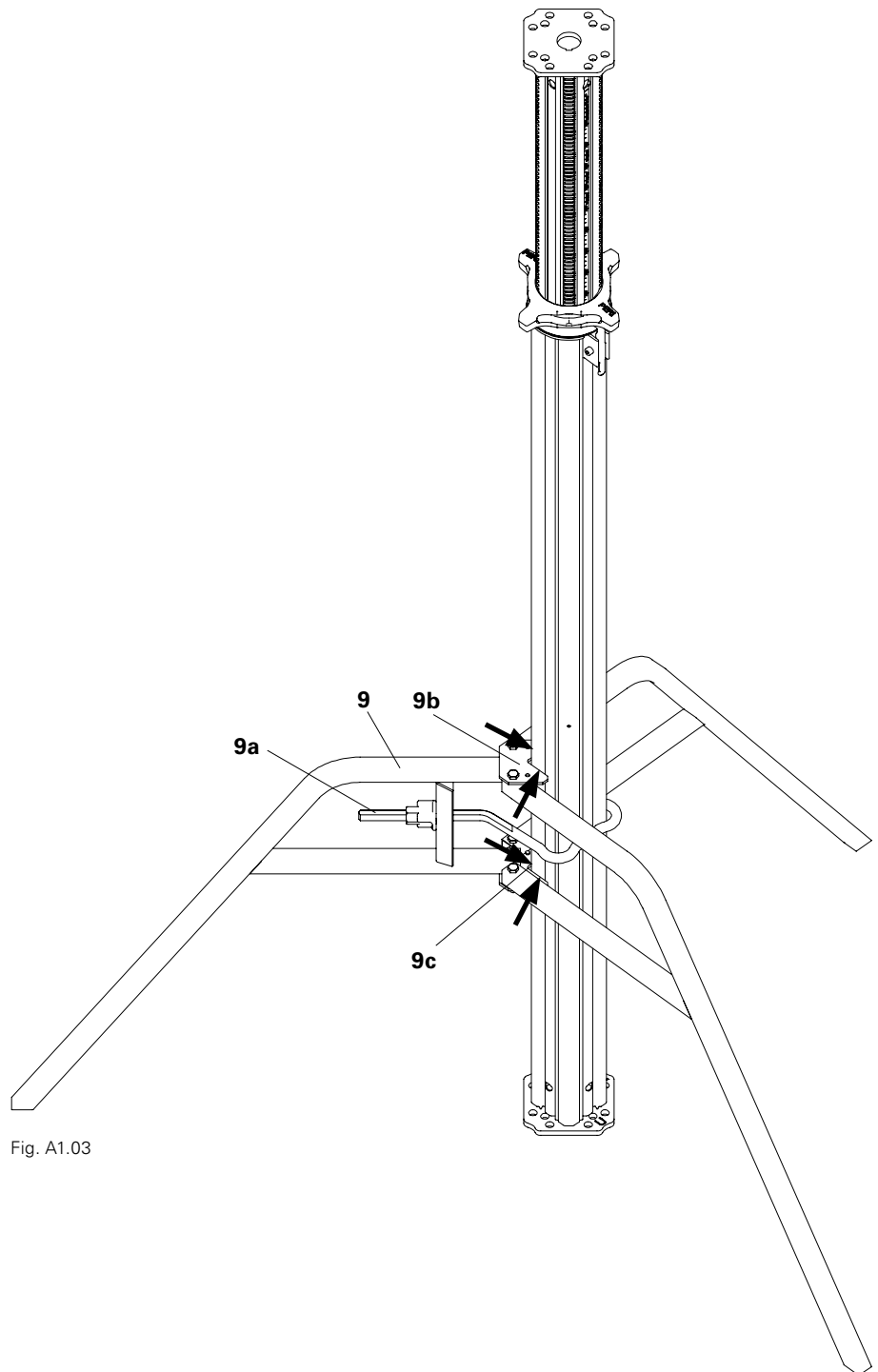

Fig. A1.03

## Releasing the Slab Prop under load



For loads > 60 kN, use the Wing Nut Spanner HD!

### Dismantling

1. Release the Adjusting Collar and set load-free with:
  - hammering the lowering cam (Fig. A2.01a)
  - Wing Nut Spanner HD Item no. 022027 (Fig. A2.01b)
2. Remove the Slab Prop.
3. Dismantle the Slab Prop.
  - Press the Safety Hook down.
    - Inner Tube with Adjusting Collar is released.
  - Pull out the Inner Tube a short distance and spindle Adjusting Collar back to the End Plate.
  - Push in the Inner Tube until the Adjusting Collar lies against the rubbing plate.
    - Safety Hook locks the Inner Tube in position.
4. Place the Slab Prop in the Ring Pallet.



See Section A5 "Storage and Transportation".



The Wing Nut Spanner HD

- facilitates effortless and silent loosening of the Adjusting Collar – even when the props are placed under maximum load. Max.  $F = 0.95$  kN.
- can be extended using the Scaffold Tube  $\varnothing 48.3 \times 3.2$  mm.

Outer Tube bottom

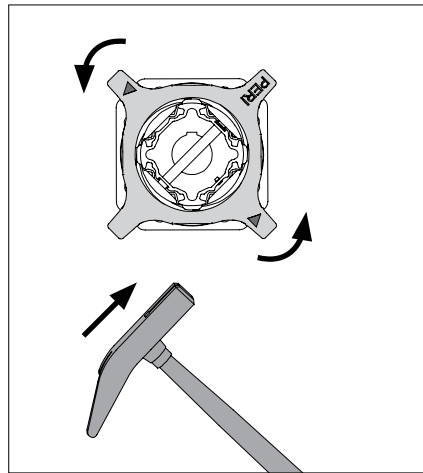

Fig. A2.01a

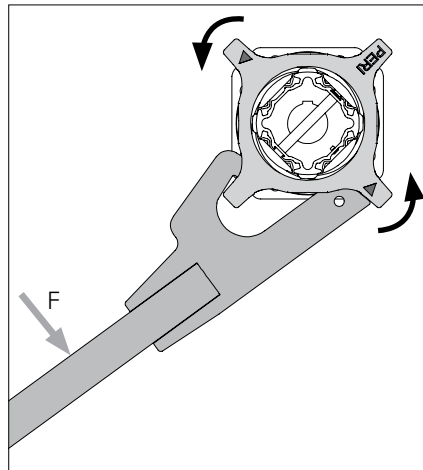
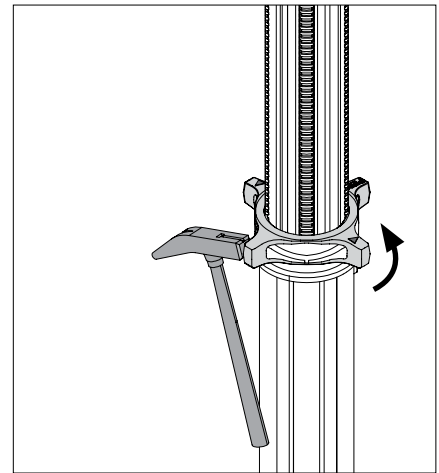
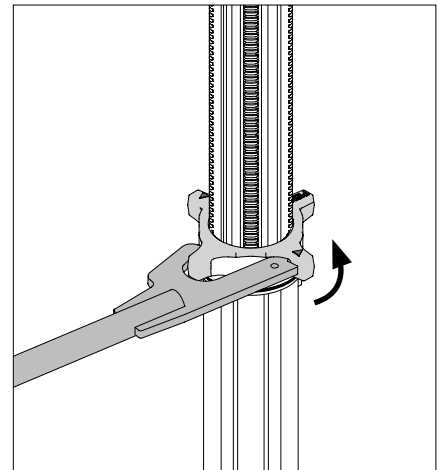

Fig. A2.01b



## Brace Clamp

Item no. 027790

Used as an alternative assembly aid for high Slab Props from approx. 4 m using bracing boards 3 x 15 cm.



- Brace Clamps are not suitable for a planned transfer of horizontal loads!
- Brace Clamps (**10**) are simply assembly aids for shuttering and striking procedures.
- As an option, Universal Tripods can be used as additional assembly aids.

### Assembly

1. Pull the narrow side of the wedge (**10a**) out of the clamp.
2. Place Brace Clamp (**10**) around the tube of the Slab Prop.
3. Insert board in the open side of the clamp.
4. Put the wedge back into recess of the clamp and hammer in securely. -> The wedge secures the board.
5. Mount additional bracing boards by means of Brace Clamps. (Fig. A3.01)



- Are the Slab Props in a perpendicular position?
- Have all wedges been securely fixed?
- Are all wedges securing the boards?

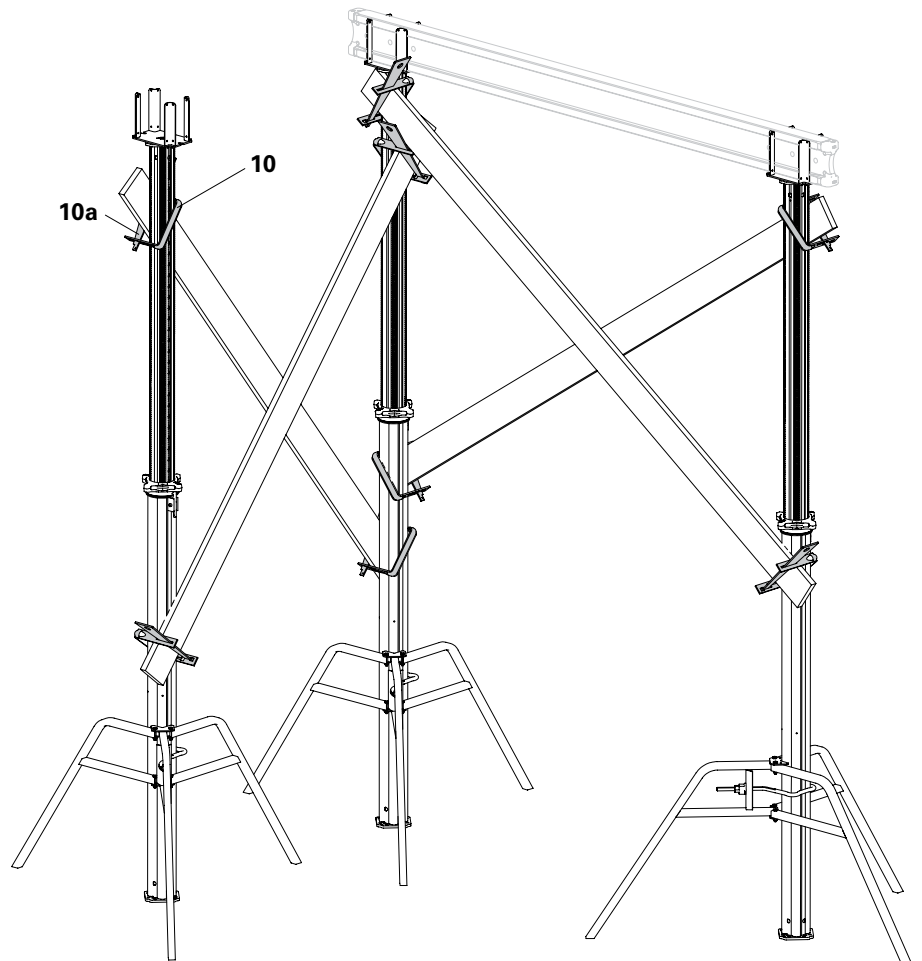

Fig. A3.01

## Base MP 50

Item no. 027310

Used to extend the Slab Prop by 50 cm.  
Automatic centring of the Slab Prop by means of centring pins.

Two Clamping Claws connect the Base MP 50 to the Slab Prop.

The MULTIPROP Slab Prop can be mounted on the Base MP 50 with the Inner or Outer Tube.



Take into account separate tables with permissible prop load!

### Assembly

1. Place the Slab Prop on the Head Plate (11a) of the Base MP 50 that the two centring pins (11b) lock into the holes of the End Plate.
2. Position the Clamping Claws (11c) with the hammer on the End Plate of the Slab Prop.  
Base MP 50 (11) is now connected to the Slab Prop.

(Fig. A3.02)



Are the two Clamping Claws fully set on the End Plate?



Through the use of the Base MP 50, the same type of prop can be used at different heights.

### Dismantling

Release clamping claws with a hammer.

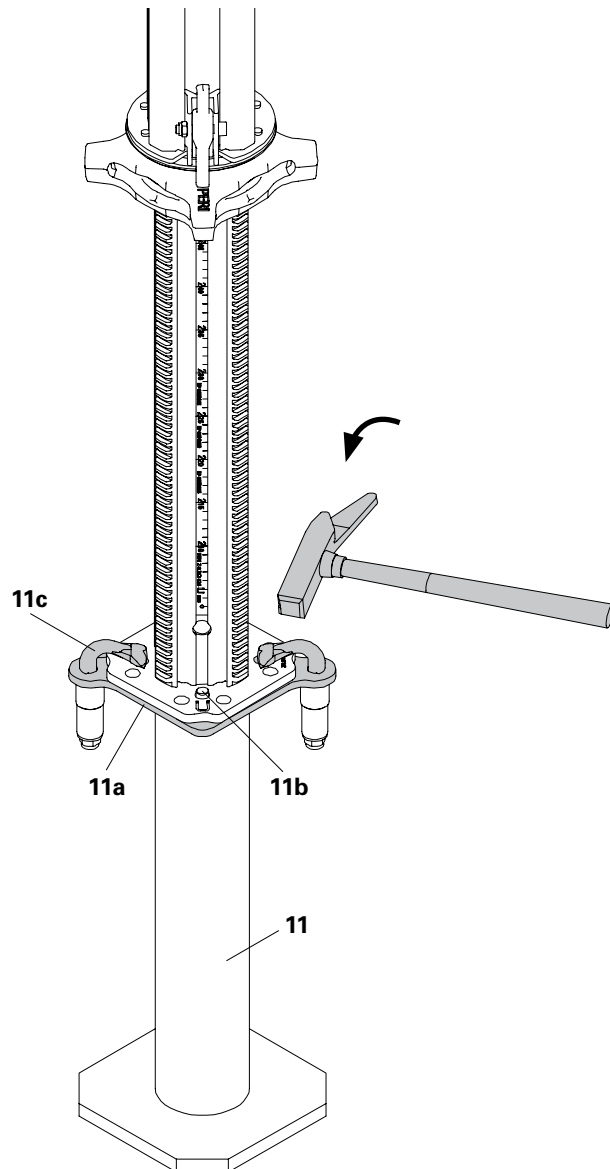

Fig. A3.02



## Non-use of damaged parts

⇒ Do not use Slab Props with broken or damaged nuts!  
(Fig. A4.01a)

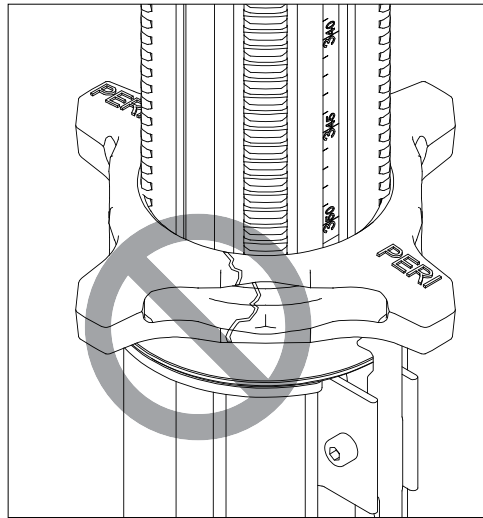

Fig. A4.01a

⇒ Do not use Slab Props with bent End Plates or split weld seams on the End Plates!  
(Fig. A4.01b)

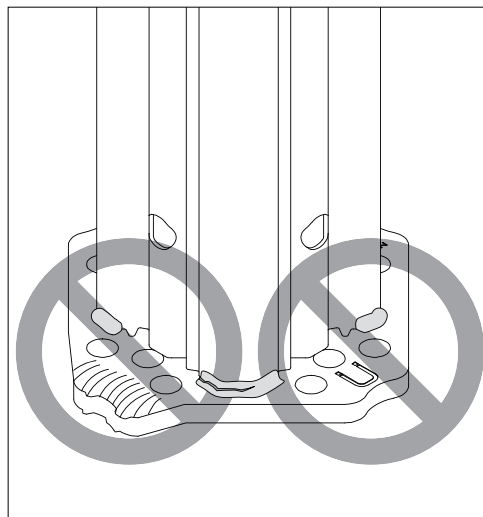

Fig. A4.01b

⇒ Do not use Slab Props with bent rubbing plates!  
(Fig. A4.01c)

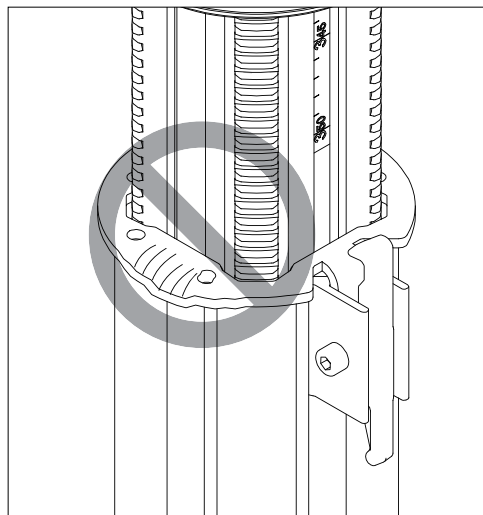

Fig. A4.01c





## Ensuring Slab Props are in a perpendicular position

⇒ Slab Props must always be in a vertical position.

(Fig. A4.02a)

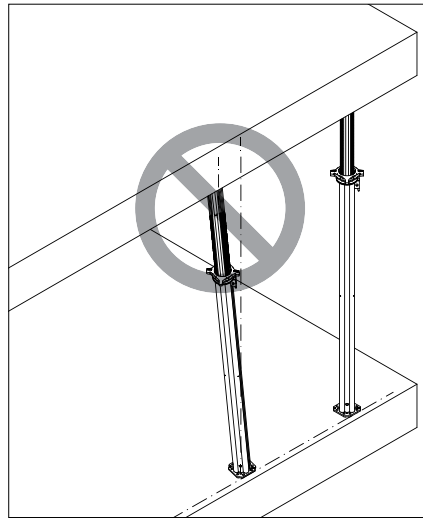

Fig. A4.02a



## Using only full-faced support surfaces

⇒ End Plates of the Slab Props must always lie completely flat against the contact surface.

If necessary, fill and secure the gap with a wedge.

(Fig. A4.02b + A4.02c)

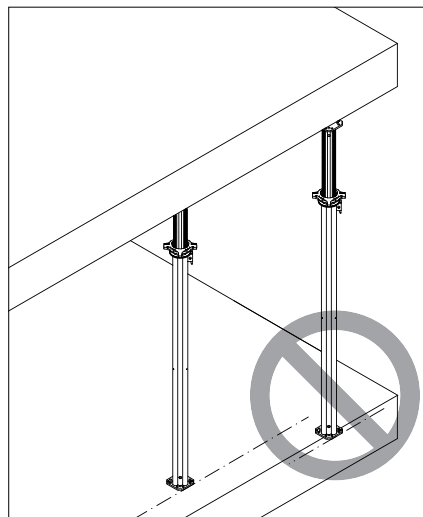

Fig. A4.02b

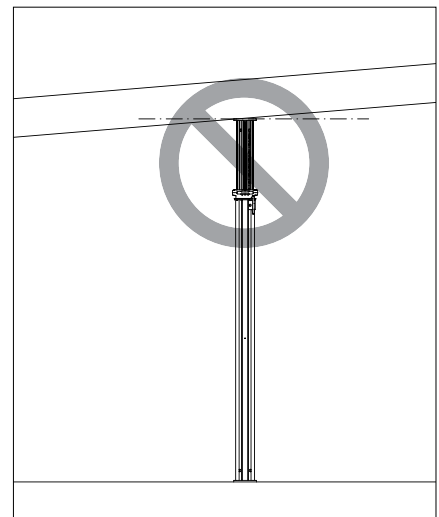

Fig. A4.02c



## Non-loadable installation surface

⇒ Slab Props must always be positioned on sufficiently load-bearing and level surfaces.

(Fig. A4.03a + A4.03b)

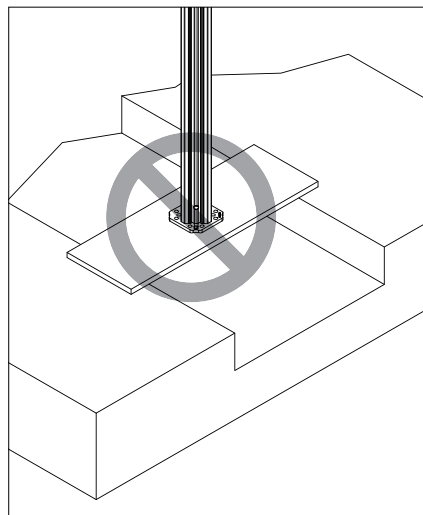

Fig. A4.03a

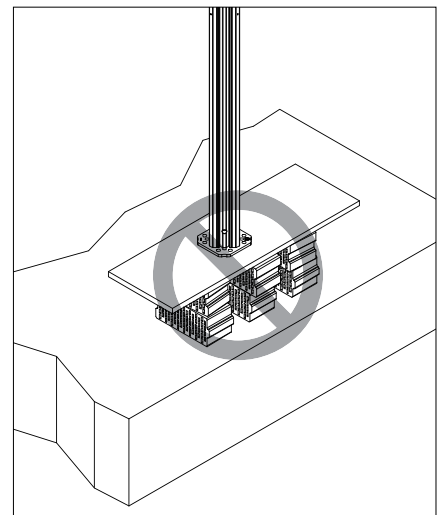

Fig. A4.03b



## Not connecting several Slab Props to each other

⇒ If the clearance is too large, a longer Slab Prop or Shoring Tower must be used, e.g. MULTIPROP System with MRK Frames.  
(Fig. A4.04)

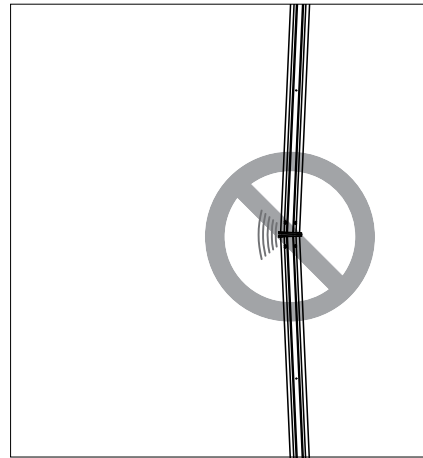

Fig. A4.04



## Do not use with the Tilting Forkhead MKK or Tilting Base MKF

⇒ If the clearance is too large, a longer Slab Prop or Shoring Tower must be used, e.g. MULTIPROP System with MRK Frames.  
(Fig. A4.05)

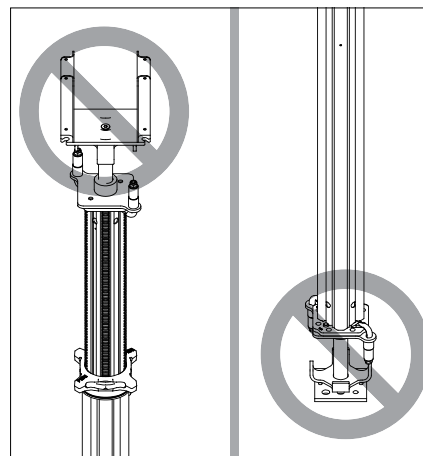

Fig. A4.05



## Do not use to support formwork elements

⇒ Use designated support equipment, e.g. Push-Pull Props or Brace Frames.  
(Fig. A4.06)

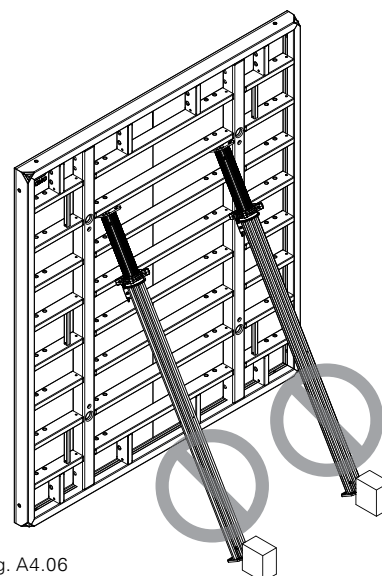

Fig. A4.06



## Do not use as a trench strut

⇒ Always use a designated trench strut.  
(Fig. A4.07)

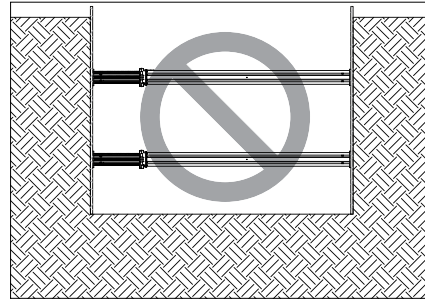

Fig. A4.07



## Do not use as anti-fall protection

⇒ Use designated anti-fall protection,  
e.g. PROKIT EP 110 or EP 200.  
(Fig. A4.08)

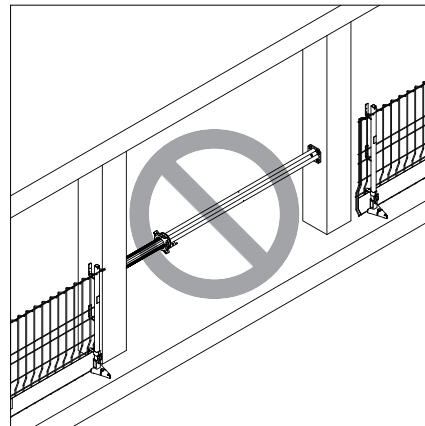

Fig. A4.08



## Do not use as a Guardrail Holder

⇒ Use designated anti-fall protection,  
e.g. PROKIT EP 110 or EP 200.  
(Fig. A4.09)

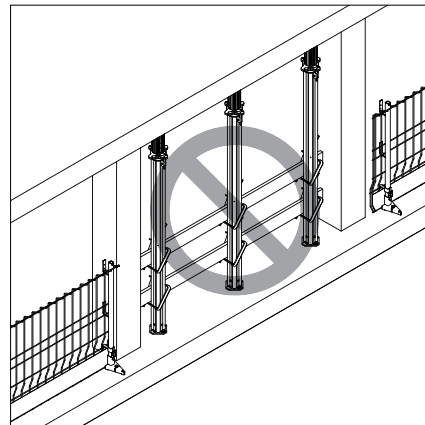

Fig. A4.09



- Store and transport components ensuring that no unintentional change in their position is possible.
- Detach lifting accessories and slings from the lowered components only if they are in a stable position and no unintentional change is possible.
- Do not drop the components.
- Use PERI lifting accessories and slings as well as only the lifting points provided on the component.
- During the moving procedure
  - ensure that components are picked up and set down so that unintentional falling over, falling apart, sliding, falling down or rolling is avoided.
  - no persons are allowed to remain under the suspended load.
- The access areas on the construction site must be free of obstacles and tripping hazards, as well as being slip-resistant.
- For transportation, the surface used must have sufficient load-bearing capacity.
- Use original PERI storage and transport systems, e.g. Crate Pallets, Pallets or Stacking Devices.
- Follow Instructions for Use for PERI Pallets and Stacking Devices!
- Follow PERI packaging guidelines!
- Transport units must be correctly stacked and secured!

PERI Pallets (14) are suitable for lifting by a crane or forklift. When using a crane, 4-sling lifting gear is used to move the pallets. During fork-lift operations, the pallets can be moved either by a fork-lift truck or by using the PERI Lifting Trolley. All pallets can be lifted using the longitudinal and front sides. Max. number of pallets in accordance with packaging guidelines.



The Safety Hook (3) prevents the Inner Tube (2) from slipping out and must be engaged.

## Storage



Store and transport Slab Props of the same size!(Fig. A5.01 + A5.02)

Delivery unit: 25 pieces

## Transportation



- Ensure loads are correctly secured during transport!
- Use tension belts or steel bands.

The number of pallets that can be transported depends on the respective national traffic regulations.

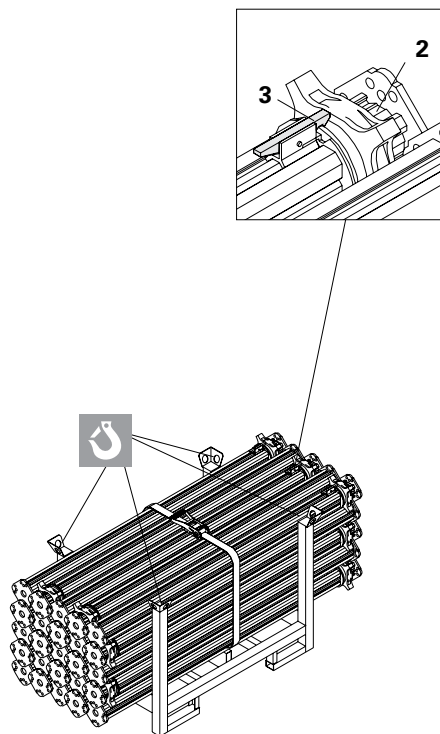

Fig. A5.01

Example: MULTIPROP Slab Props positioned horizontally in a Pallet RP-2 and secured by means of a tension belt.

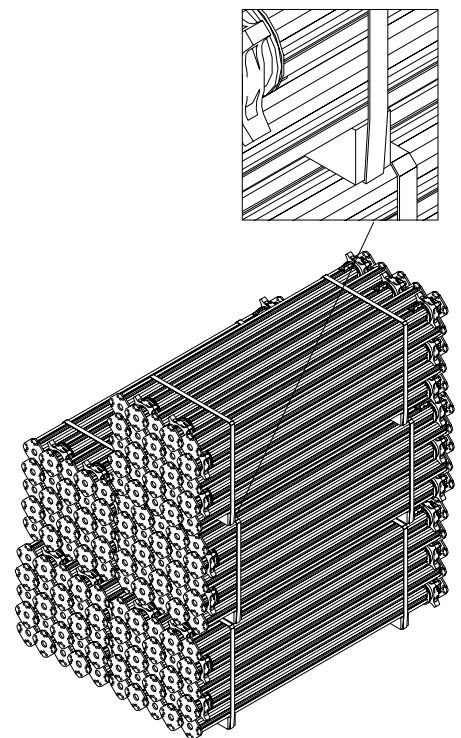

Fig. A5.02

Example: MULTIPROP Slab Props stacked using battens and secured by means of a steel band.

## MULTIPROP 120, 250, 350

Permissible prop load [kN] according to the type test						
Extension length [cm]	MP 120 L = 0.80 – 1.20 m		MP 250 L = 1.45 – 2.50 m		MP 350 L = 1.95 – 3.50 m	
	Outer Tube bottom	Inner Tube bottom	Outer Tube bottom	Inner Tube bottom	Outer Tube bottom	Inner Tube bottom
80	89.3	102.0				
90	89.0	102.0				
100	88.7	102.0				
110	88.7	98.0				
120	88.7	94.0				
130						
140						
150			99.3	94.0		
160			99.3	94.0		
170			99.3	94.0		
180			97.2	94.0		
190			92.9	94.0		
200			88.7	94.0	96.0	94.7
210			86.5	94.0	93.1	94.7
220			84.4	94.0	90.1	94.7
230			82.5	92.4	87.5	94.1
240			80.9	89.2	85.1	93.1
250			79.3	86.0	82.7	92.0
260					79.3	88.7
270					76.0	85.3
280					73.3	82.7
290					70.7	80.0
300					68.7	77.0
310					66.7	74.0
320					63.1	71.0
330					59.6	68.0
340					54.7	61.5
350					49.8	54.9

Permissible load-bearing capacity (DIN EN 16031)



For releasing loads > 60 kN, use the Wingnut Spanner HD, item no. 022027.

## MULTIPROP 480, 625

Permissible prop load [kN] according to the type test				
Extension length [cm]	MP 480 L = 2.60 – 4.80 m		MP 625 L = 4.30 – 6.25 m	
	Outer Tube bottom	Inner Tube bottom	Outer Tube bottom	Inner Tube bottom
260	88.7	94.0		
270	87.8	92.3		
280	87.0	90.7		
290	86.2	89.0		
300	85.3	87.3		
310	80.2	84.9		
320	75.1	82.5		
330	70.0	80.0		
340	66.6	77.3		
350	63.2	74.7		
360	59.7	72.0		
370	56.2	67.4		
380	52.8	62.7		
390	49.3	58.1		
400	46.3	54.1		
410	43.3	50.0		
420	40.3	45.9		
430	38.0	43.3	57.9	45.7
440	35.7	40.8	56.3	45.7
450	33.5	38.2	54.7	45.7
460	31.2	35.6	52.5	45.1
470	28.9	33.1	50.2	44.5
480	26.7	30.5	47.8	43.6
490			45.1	42.5
500			42.4	41.3
510			39.8	39.9
520			37.2	38.5
530			34.9	37.0
540			32.9	35.6
550			30.9	34.1
560			29.3	32.6
570			27.7	31.1
580			26.3	29.5
590			25.0	27.9
600			23.7	26.2
610			22.6	24.8
620			21.5	23.4
625			21.0	22.7



For releasing loads > 60 kN, use the Wingnut Spanner HD, item no. 022027.

Permissible load-bearing capacity (DIN EN 16031)

## MULTIPROP 120, 250, 350 with Base MP 50

Permissible prop load [kN] according to the type test						
Overall height [cm] (Prop extension + 50 cm)	MP 120 + MP 50 L = 1.30 – 1.70 m		MP 250 + MP 50 L = 1.95 – 3.00 m		MP 350 + MP 50 L = 2.45 – 4.00 m	
	Outer Tube bottom	Inner Tube bottom	Outer Tube bottom	Inner Tube bottom	Outer Tube bottom	Inner Tube bottom
130	88.0	84.7				
140	88.0	83.3				
150	88.0	82.0				
160	86.3	80.3				
170	84.7	78.7				
180						
190						
200			89.3	94.0		
210			89.3	94.0		
220			89.3	94.0		
225			89.3	94.0		
230			88.1	93.7		
240			85.7	93.2		
250			83.3	92.7	88.7	85.3
260			79.9	88.9	88.7	85.3
270			76.4	85.2	88.7	85.3
280			72.9	80.5	86.4	85.3
290			69.3	74.9	81.9	85.3
300			65.7	69.3	77.3	85.3
310					73.3	82.3
320					69.3	79.3
330					65.6	72.1
340					61.8	64.9
350					57.4	60.7
310					53.1	56.4
370					49.4	52.2
380					45.7	48.0
390					42.4	44.0
400					39.1	40.0

Permissible load-bearing capacity (DIN EN 16031)



For releasing loads > 60 kN,  
use the Wingnut Spanner HD,  
item no. 022027.



## MULTIPROP 480, 625 with Base MP 50

Permissible prop load [kN] according to the type test				
Overall height [cm] (Prop extension + 50 cm)	MP 480 + MP 50 L = 3.10 – 5.30 m		MP 625 + MP 50 L = 4.80 – 6.75 m	
	Outer Tube bottom	Inner Tube bottom	Outer Tube bottom	Inner Tube bottom
310	88.7	81.3		
320	86.3	81.0		
330	84.0	80.7		
340	81.7	80.3		
350	79.3	80.0		
360	73.3	75.8		
370	67.2	71.5		
380	61.2	67.3		
390	56.9	62.9		
400	52.6	58.4		
410	48.3	53.9		
420	45.5	50.1		
430	42.6	46.3		
440	39.8	42.5		
450	37.6	40.0		
460	35.5	37.5		
470	33.3	35.0		
480	31.7	33.2	48.7	44.5
490	30.0	31.4	47.5	44.4
500	28.4	29.6	46.3	44.3
510	26.8	27.8	44.6	43.1
520	25.1	26.1	42.9	41.8
530	23.5	24.3	41.1	40.4
540			39.2	38.8
550			37.3	37.1
560			35.3	35.6
570			33.3	34.0
580			31.5	32.5
590			29.8	31.0
600			28.1	29.5
610			26.7	28.1
620			25.3	26.7
630			24.1	25.4
640			22.9	24.2
650			21.8	22.9
660			20.8	21.8
670			19.8	20.6
675			19.3	20.0



For releasing loads > 60 kN, use the Wingnut Spanner HD, item no. 022027.

Permissible load-bearing capacity (DIN EN 16031)

# MULTIPROP Slab Props



Item no.	Weight kg
027288	10.100
027289	15.400
027290	19.400
027291	24.700
027305	34.500

- MULTIPROP MP**
- MULTIPROP MP 120**
- MULTIPROP MP 250**
- MULTIPROP MP 350**
- MULTIPROP MP 480**
- MULTIPROP MP 625**

Slab prop made of aluminium. Used as individual prop as well as in combination with MULTIPROP Frames MRK to form towers.

min. L	max. L
800	1200
1450	2500
1950	3500
2600	4800
4300	6250

### Technical Data

Permissible load: see PERI Design Tables.

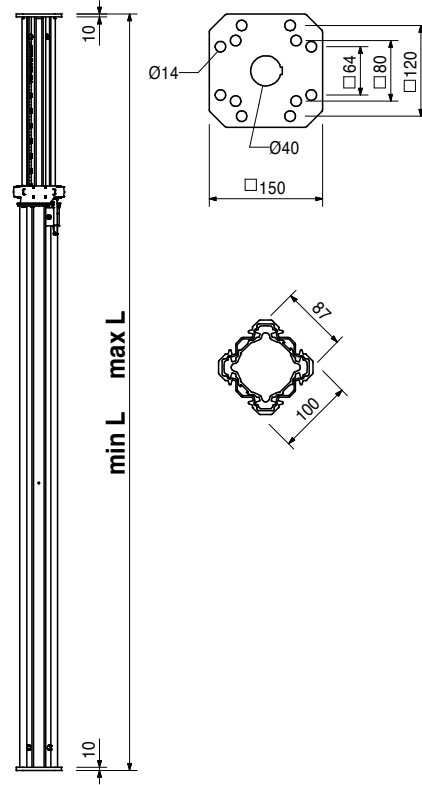
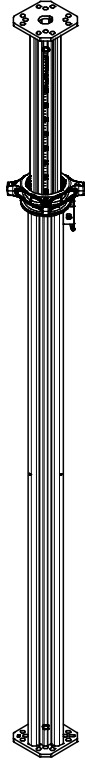

028000 9.190

### Universal Tripod 57 – 120

Erection aid for slab props with Ø 57 – 120 mm and 120 x 120 mm. Can also be used in combination with MULTIPROP MP Slab Props and all slab props with Base MP 50.

### Note

Only use as erection aid!

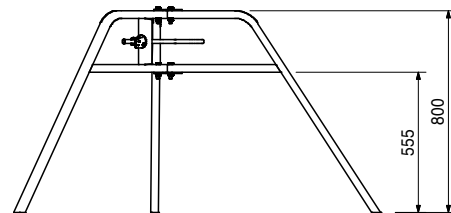
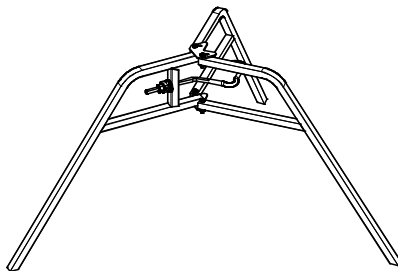

# MULTIPROP Slab Props



Item no.	Weight kg
027790	2.460

## Brace Clamp HL, galv., 76 – 120 mm

For assembly of 3 x 15 cm stiffening boards at slab props  $\varnothing$  76 – 89 mm and 100 x 100 mm to 120 x 120 mm.

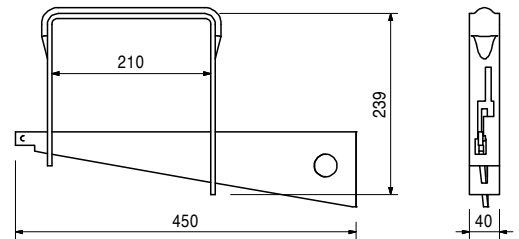
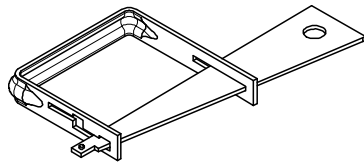

022027	3.600
--------	-------

## Wing Nut Spanner HD

For easy release of the Head Spindle HDK 45, the Head Spindle TR 110-80/55 and the MULTIPROP Slab Prop.

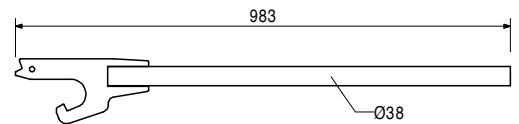
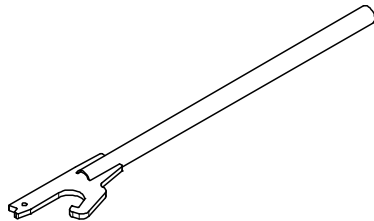

027310	8.900
--------	-------

## Base MP 50

For use with slab props with an end plate thickness of 6 – 10 mm. With clamped quick-release fastener.

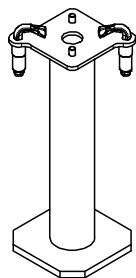

### Note

Permissible load: see PERI Design Tables.

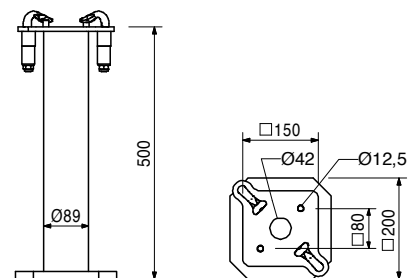

# MULTIPROP Slab Props



Item no.	Weight kg
103434	38.500
103429	45.300

**Pallets RP-2, galv.**

**Pallet RP-2 80 x 120, galv.**

**Pallet RP-2 80 x 150, galv.**

For stacking and transportation of formwork and scaffolding components.

## Note

Follow Instructions for Use!

## Technical Data

Permissible load-bearing capacity 1.5 t.

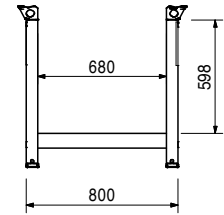
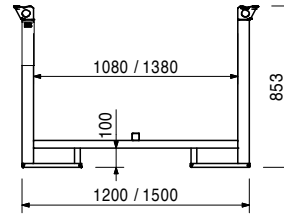
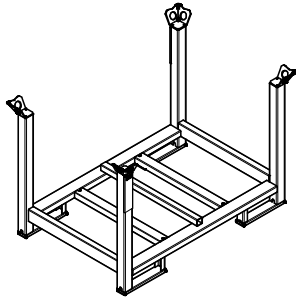



**The optimal System  
for every Project and  
every Requirement**



**Wall Formwork**



**Column Formwork**



**Slab Formwork**



**Climbing Systems**



**Bridge Formwork**



**Tunnel Formwork**



**Shoring Systems**



**Construction Scaffold**



**Facade Scaffold**



**Industrial Scaffold**



**Access**



**Protection Scaffold**



**Safety Systems**



**System-Independent  
Accessories**



**Services**



**PERI GmbH**  
**Formwork Scaffolding Engineering**  
 Rudolf-Diesel-Strasse 19  
 89264 Weissenhorn  
 Germany  
 Tel. +49 (0)7309.950-0  
 Fax +49 (0)7309.951-0  
 info@peri.com  
 www.peri.com

