

ALIMAK STS 300 SCAFFOLDING TRANSPORT SYSTEM

User, installation and maintenance manual

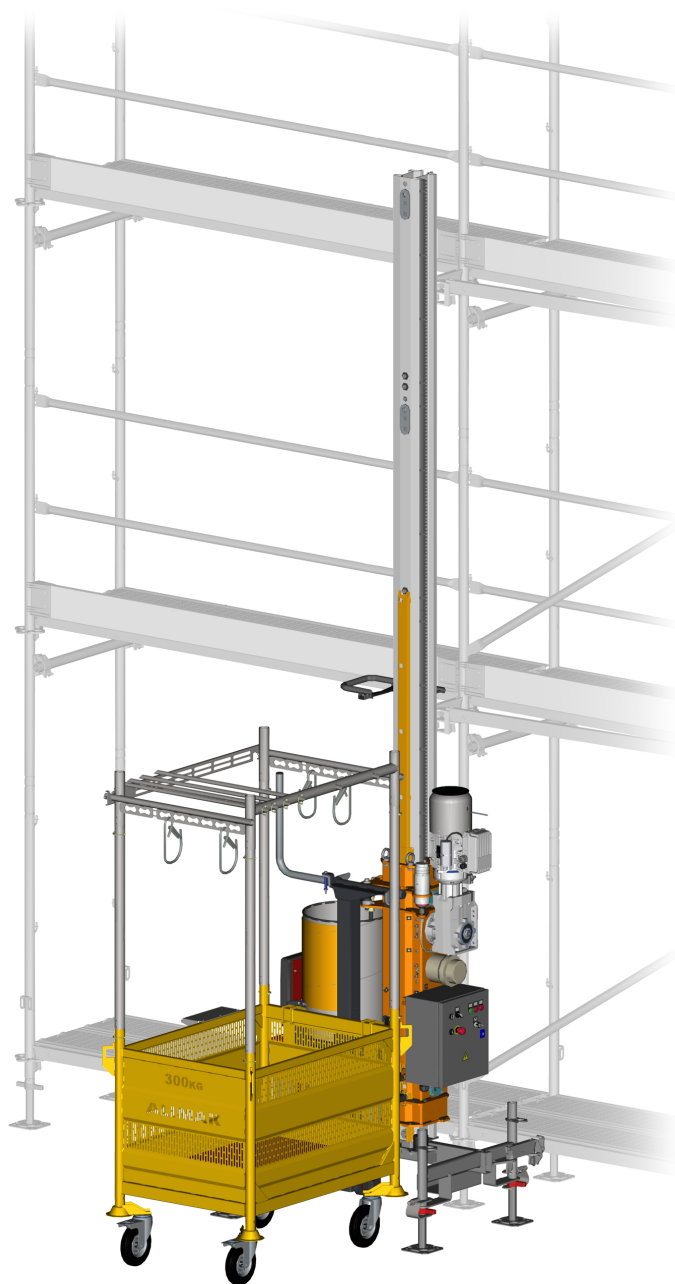

AL-ST001

CE

ALIMAK STS 300 SCAFFOLDING TRANSPORT SYSTEM

EN-AL-03-00-0001-01

Limited Warranty

Consult the warranty requirements in the general terms and conditions.

ALIMAK

Alimak Manufacturing S.L.
Calle Ángeles (los), Num. 88
Pol. Industrial Centrovía
50198 Muela (La)
(Zaragoza) Spain
P: +34 976 149524
E: STS300.uk@alimakgroup.com
<https://my.alimak.com>



Contents

1	Introduction	4
1.1	Symbols	4
1.2	Terms and definitions	4
1.3	Observations	4
1.4	Cautions	4
2	General information	6
2.1	Purpose	6
2.2	Scope	6
2.3	Exclusions	6
2.4	Technical specifications	6
2.4.1	General specifications	6
2.4.2	Electrical specifications	7
2.4.3	Environmental specifications	7
2.5	Informative signs and documentation	7
2.6	Dimensions	8
2.6.1	Alimak STS 300	8
3	Description	11
3.1	Overview of the scaffolding transport system	11
3.1.1	Alimak STS 300	11
3.2	Scaffolding transport system parts	12
3.2.1	Base unit	12
3.2.2	Mast	15
3.2.3	Box	15
3.3	Controls	16
3.3.1	Main control box	16
3.3.2	Base frame control box	17
3.3.3	User control station	17
3.3.4	Free fall test control station	17
3.4	Safety devices	18
3.4.1	Bottom limit switch	18
3.4.2	Emergency bottom limit switch	18
3.4.3	Level sensor	18
3.4.4	Top limit sensor	18
3.4.5	Emergency top limit sensor	18
3.4.6	2 m zone switch	18
3.4.7	Box detection switch	18
3.4.8	Overload detection device	18
3.4.9	Box rotation switch	19
3.4.10	Overspeed safety device switch	19
3.4.11	Box fastening system switch	19
3.4.12	Acoustic buzzer	19
3.5	Guided trailing cable management system	20
3.6	Base unit lifting device	20
4	Transport	21
4.1	General transport requirements	21

4.2 Delivery inspection	21
5 Installation, use and inspection	22
5.1 Installation and usage requirements	22
5.1.1 Soil compression	22
5.2 Electrical power supply	22
5.3 Installation and levelling of the base unit	23
5.3.1 Type 1 installation	24
5.3.2 Type 2 installation	26
5.4 Installation of the mast	28
5.4.1 Connection of the mast sections	28
5.4.2 Anchor support	28
5.4.3 Connecting the mast to the scaffolding	28
5.4.4 Cable guide	29
5.4.5 Dimensions	30
5.4.6 Forces on the anchors	31
5.5 Electrical connections	31
5.6 Installation of the box	31
5.6.1 Assembly of the box	31
5.6.2 Assembly of the box wheels	32
5.6.3 Assembly of the auxiliary box	32
5.6.4 Adjusting the height of the anchoring system	33
5.6.5 Coupling the box to the anchoring system	33
5.6.6 Uncoupling the box from the anchoring system	34
5.7 Adjusting the top limit sensor	35
5.8 Inspection prior to use	36
5.8.1 General	36
5.8.2 Control and safety devices	37
5.9 Prohibited uses	38
5.10 Using the scaffolding transport system	38
5.11 Loading materials into the box and unloading them from it	39
5.11.1 Loading materials into the box	39
5.11.2 Unloading the materials from the scaffolding	40
5.11.3 Example of how to unload materials	42
5.11.4 Installation of the mast prior to installation of the upper level of the scaffolding	43
5.12 Disassembly	44
5.13 Troubleshooting	45
6 Maintenance	52
6.1 Maintenance planning	52
6.1.1 General	53
6.1.2 Control and safety devices	54
6.1.3 Overspeed safety device test	57
6.1.4 Emergency limit switch and sensor	57
6.1.5 Drive system	58
6.1.6 Rack and pinion	58
6.1.7 Lubrication system	59
6.1.8 Turning system	59
6.1.9 Box fastening system	60

6.1.10 Guiding system	60
6.1.11 Cable management system	61
6.1.12 Mast	61
6.1.13 Control boxes	62
6.1.14 Checking the overload system	62
6.1.15 Informative signs and documentation	62
6.1.16 Replacing the motor start-up capacitor	62
6.1.17 Overspeed safety device overhaul	63
6.1.18 Replacing the overspeed safety device	63
6.1.19 Replacing the emergency top limit sensor	63
Testing and adjusting the electromagnetic motor brake	64
Measuring the wear of the rack and drive pinion	66
Checking the lubrication system	67
Measuring the wear of the guiding system	69
Lubrication of the cable management system	70
Adjusting the overload system	71
Lubricants	72
Inspection prior to use checklist	73
User log	74
Installation and maintenance checklist	77
Installation and maintenance log	79
Change log	83

1 Introduction

EN-AL-04-02-0000-01

This manual provides assembly, modification and disassembly instructions. It is part of, but not a substitute for, the customer-specific methodology statement.

When PERI elements are used, the PERI manual will take precedence over the Alimak manual.

1.1 Symbols

EN-AL-04-02-0001-01

DANGER



Immediate or potentially imminent danger.
Failure to observe may result in injuries or damages:
 - Death or serious injury.

WARNING



Potentially hazardous situation.
Failure to observe may result in injuries or damages:
 - Moderate injury or material damage.

CAUTION



Dangerous situation.
Failure to observe may result in injuries or damages:
 - Minor or moderate injury.

NOTICE



Useful tips for an optimum work process.
Failure to observe may result in injuries or damages:
 - None.

1.2 Terms and definitions

EN-AL-04-04-0001-01

Terms	Definitions
Certified technician	Person who has received relevant training from Alimak or a qualified instructor associated with the intended work and who holds valid certification (current) for the task in question.
User	Person who has received relevant training associated with using the Alimak scaffolding transport system and performing the corresponding daily inspections and who holds valid familiarisation documentation (current) for the task in question.
Manual descent (also: descent without electrical power supply)	Action performed to descend the scaffolding transport system at a controlled speed without electrical power, by releasing the drive system's electromagnetic brake manually.

1.3 Observations

EN-AL-04-01-0001-01

Only persons who have received the required familiarisation are authorised to use the scaffolding transport system in accordance with the instructions in this manual.

Only the revision version of the manual supplied with the product is valid except with written authorisation from the manufacturer.

This manual must always be available to the personnel responsible for the installation, maintenance and operation of the scaffolding transport system.

Additional copies may be requested from the manufacturer.

The contents of this manual (processes, components, descriptions, instructions, recommendations, requirements, etc.) are subject to change without prior notice.

Any additional cost related to or arising from any changes to the manuals does not entitle the customer to any form of compensation or other legal remedies.

NOTICE



The pictures and diagrams in this manual may not reflect the exact appearance, colours or layout of the Product. This does not have any impact on the Product's functionality or safety.

1.4 Cautions

EN-AL-04-03-0001-01

CAUTION



Risk of accident. Follow all of the instructions in order to prevent injuries.

Cautions about personnel:

- Should be of legal age.
- Should be familiar with the accident prevention instructions and receive adequate training in terms of occupational health and safety.
- Must not use the scaffolding transport system under the influence of alcohol or drugs that might compromise safety at the workplace.
- Must wear PPE personal protective equipment (safety helmet, safety footwear, gloves, etc.)
- Only certified technicians are authorised to check the functional safety of the system in case of repair or replacement of any component.
- Only certified technicians are authorised to check/repair electrical installations and repair the drive system, overspeed safety device and suspension system.
- In case several technicians perform the inspection and maintenance operations, the manager must appoint a supervisor.

Cautions about the use:

- Only persons with relevant familiarisation associated with using and performing daily inspections on the Alimak scaffolding transport system are authorised to use and perform daily inspections on the scaffolding transport system.
- Check that all the scaffolding transport system components are available and fully functional.
- Observe the procedures for handling and lifting loads.
- Ensure on site that the reaction forces of the system are transferred safely to the foundation and anchor.
- Do not place objects or stand under the scaffolding transport system.
- Check that nobody is on the intermediate levels of the scaffolding while the scaffolding transport system is in use.
- Remove any obstacles around the scaffolding transport system.
- Place the load so that it is stable in the box and does not exceed the maximum load capacity.
- In low light conditions, illuminate the work area to ensure sufficient visibility.
- Do not use the scaffolding transport system under adverse weather conditions, including wind speeds of more than 20 m/s, except where other more restrictive speeds are defined.
- Stop working immediately and inform the supervisor in case any damages or malfunctions occur during operation or in case circumstances arise that could jeopardise safety.

Cautions about maintenance:

- Inspect the scaffolding transport system at least once a year or according to local regulations.
- Increase the frequency of inspections in the case of a high frequency of operation or severe conditions of use.
- The scaffolding transport system is designed for a useful life of 10 years with an approximate operating frequency of 90 h/year (900 h in total).
- Switch off the electrical power supply for the scaffolding transport system before carrying out any maintenance work.
- Sign and inform about the prohibition of use during maintenance tasks.

Cautions about scaffolding transport system parts:

- Only use original Alimak parts.
- Use of non-original parts renders the manufacturer's warranty void and invalidates any type approval.
- No warranty is provided against damage resulting from reconstruction or modification of equipment or use of non-original parts that are not approved by the manufacturer.
- No modification, extension or reconstruction of the scaffolding transport system is permitted without the manufacturer's prior written consent.

NOTICE



The owner must check the need for third-party scaffolding transport system inspections with local authorities and comply with any specified standards.

2 General information

2.1 Purpose

EN-AL-05-01-0001-01

Use of the scaffolding transport system is limited to authorised users. Access to the base, assembly/disassembly and use of the transport system and the scaffolding is controlled and is prohibited for unauthorised persons.

The scaffolding transport system is only used for:

- Transporting parts for assembling/disassembling scaffolding between ground level and the highest level of the scaffolding.

2.2 Scope

EN-AL-05-02-0001-01

The Product details are described throughout this manual.

The Product comprises a scaffolding transport system consisting of:

- Base frame
- Box
- Drive system
- Overspeed safety device
- Control, safety and supply systems
- Safety devices
- Guiding system

NOTICE



This manual contains the instructions for the Alimak STS 300 scaffolding transport system.

2.3 Exclusions

EN-AL-05-03-0001-01

The user company must supply at least the following interface components that are not included in the scope of delivery of the scaffolding transport system:

- Anchor points to the scaffolding and clamps.
- Adaptation for base frame wheels.
- Base frame wheels.

NOTICE



If necessary, please contact the scaffolding manufacturer or Alimak for assistance.

2.4 Technical specifications

2.4.1 General specifications

EN-AL-05-04-0001-01

Scaffolding transport system		Alimak STS 300
General	Drive system type	Rack - pinion
	Scaffolding transport system speed	17 m/min
	Load capacity	300 kg
	Base unit weight	280 kg
	Transport dimensions (length x width x height)	1260 x 820 x 1860 mm
Base frame	Base frame dimensions (length x width x height)	1260 x 740 mm
Mast	Mast section dimensions	164 x 171 x 1005 mm
		164 x 171 x 330 mm ¹⁾
	Mast section weight	16 kg (Length: 1005 mm)
		8 kg (Length: 330 mm) ¹⁾
	Max. self-supporting height	0 m
Max. height	50 m	
Anchors	Max. height of first anchor	2 m
	Distance between anchors	2 m (max. 3 m)
	Max. permitted height without anchors	1 m
Box	Box weight (min./max.)	60 kg / 80 kg (Upper frame included)
	Box dimensions (length x width x height (min./max.))	Without wheels: 1230 x 880 x 870 / 2070 mm With wheels: 1230 x 880 x 1005 / 2205 mm

NOTICE



¹⁾ Depending on the scaffolding installation, it may be necessary to install mast sections of different lengths. [Refer to section [Installation and levelling of the base unit](#), see on page 23].

2.4.2 Electrical specifications

EN-AL-05-04-0003-01

Scaffolding transport system	Alimak STS 300
No. of motors/type	1/electric
Power	2.2 kW
Rated current	16 A
Electrical power supply	230 V/50 Hz 1 Phase + N + PE
Control and power cable	3G4 + 6x1 mm
Control circuit electrical power supply	230 VAC/50 Hz

2.4.3 Environmental specifications

EN-AL-05-04-0004-01

Scaffolding transport system	Alimak STS 300
Operating temperature	-15 °C - +40 °C
Max. noise level	90 dB (A)

2.5 Informative signs and documentation

EN-AL-06-09-0001-01

The documentation, signs and stickers included with the scaffolding transport system should always be available and legible. They provide the user with information about the scaffolding transport system and instructions regarding safety and emergency situations.

Location	Documentation
Drive unit	Serial number plate
Cable collect bin	Mast data
	Distance between anchors
	Use by authorised personnel
	Hazard warning of persons below the box
Box	Load limit / Prohibition on transporting persons
	Load position
Main control box	Electric hazard warning
Base frame control box	Electrical data of the system
	Electric hazard warning
Document holder	Manual
	Electrical diagrams

2.6 Dimensions

2.6.1 Alimak STS 300

2.6.1.1 Drive unit dimensions

EN-AL-05-05-0002-01

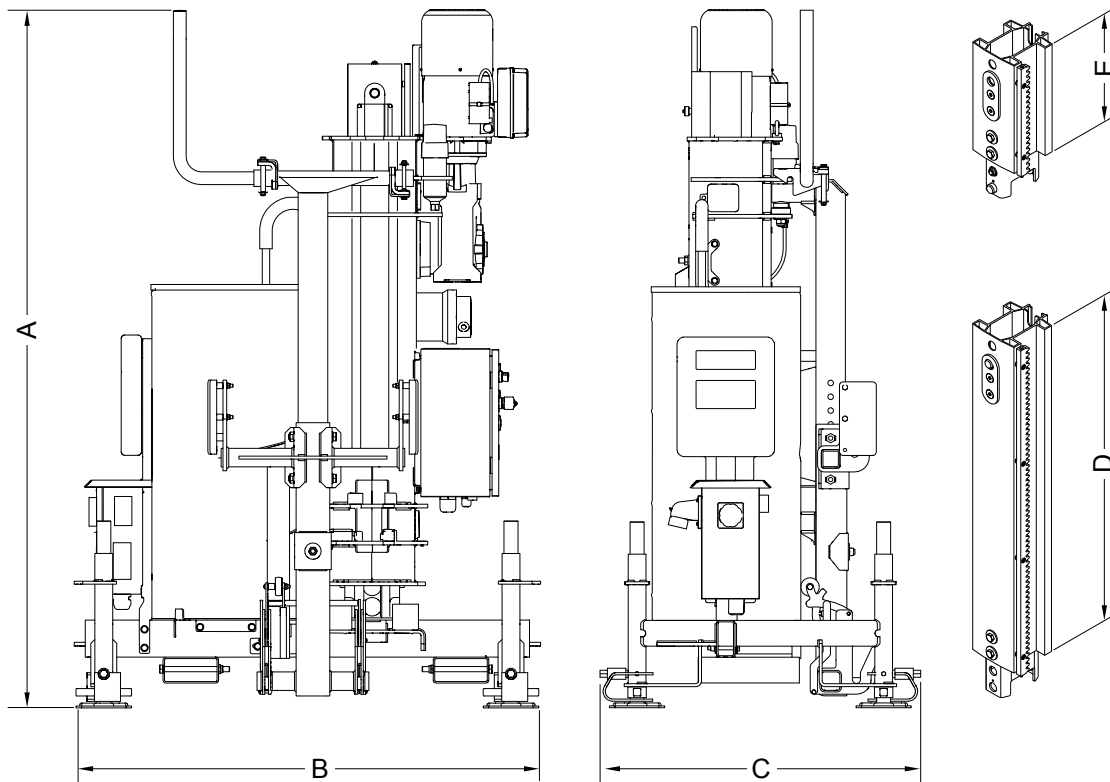

AL-ST5004a

Figure 1 : Drive unit dimensions

Drive unit dimensions

A	1860 mm
B	1260 mm
C	820 mm
D	1005 mm
E	330 mm ¹⁾

NOTICE



¹⁾Depending on the scaffolding installation, it may be necessary to install mast sections of different lengths. [Refer to section [Installation and levelling of the base unit](#), see on page 23].

2.6.1.2 Drive unit dimensions with the box anchored

EN-AL-05-05-0003-01

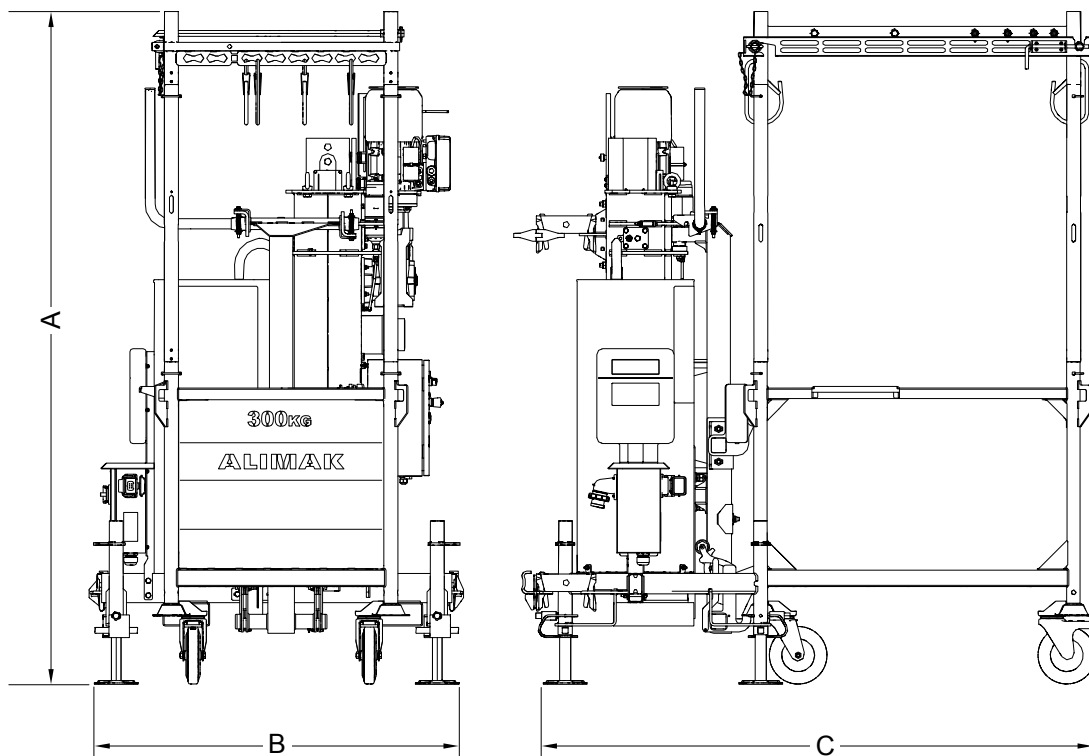

AL-ST004b

Figure 2 : Drive unit dimensions with the box anchored

Drive unit dimensions with the box anchored

A	2350 mm
B	1260 mm
C	1890 mm

2.6.1.3 Box dimensions

EN-AL-05-05-0004-01

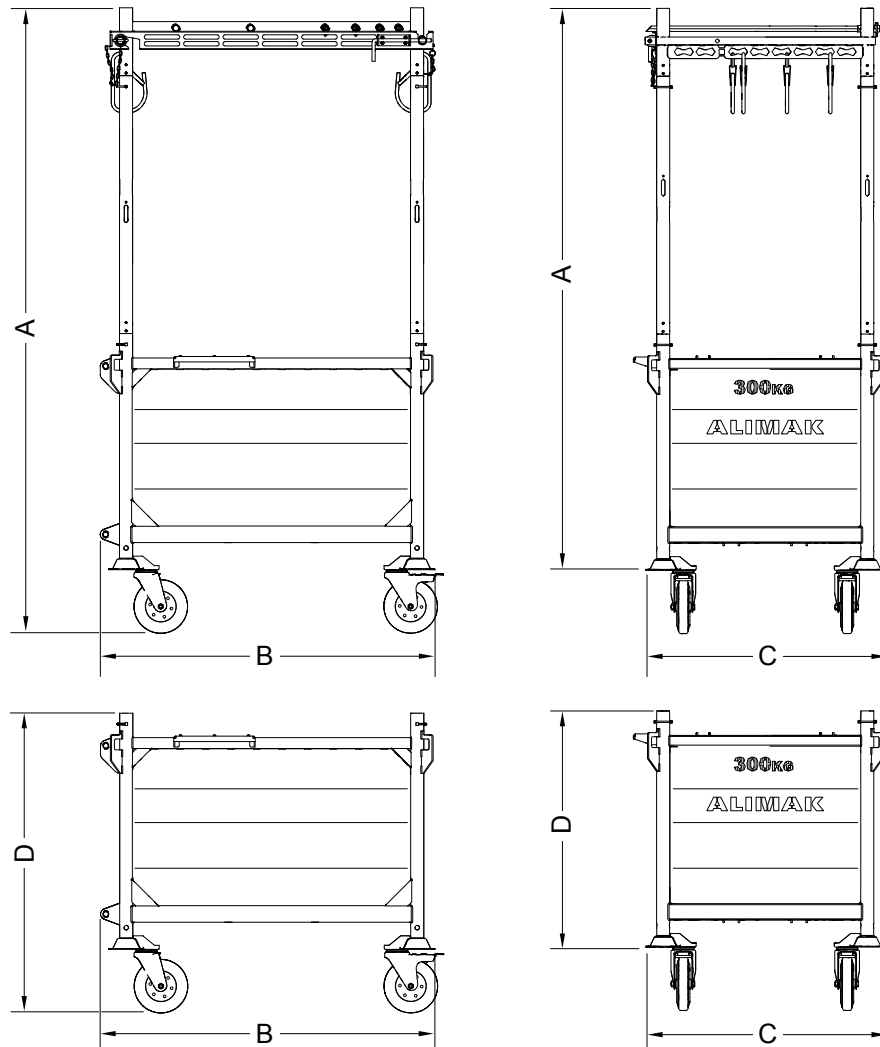

AL-STS004c

Figure 3 : Box dimensions

Box dimensions

A	Without wheels 2070 mm / With wheels 2205 mm
B	1230 mm
C	880 mm
D	Without wheels 870 mm / With wheels 1005 mm

3 Description

3.1 Overview of the scaffolding transport system

3.1.1 Alimak STS 300

EN-AL-05-04-0002-01

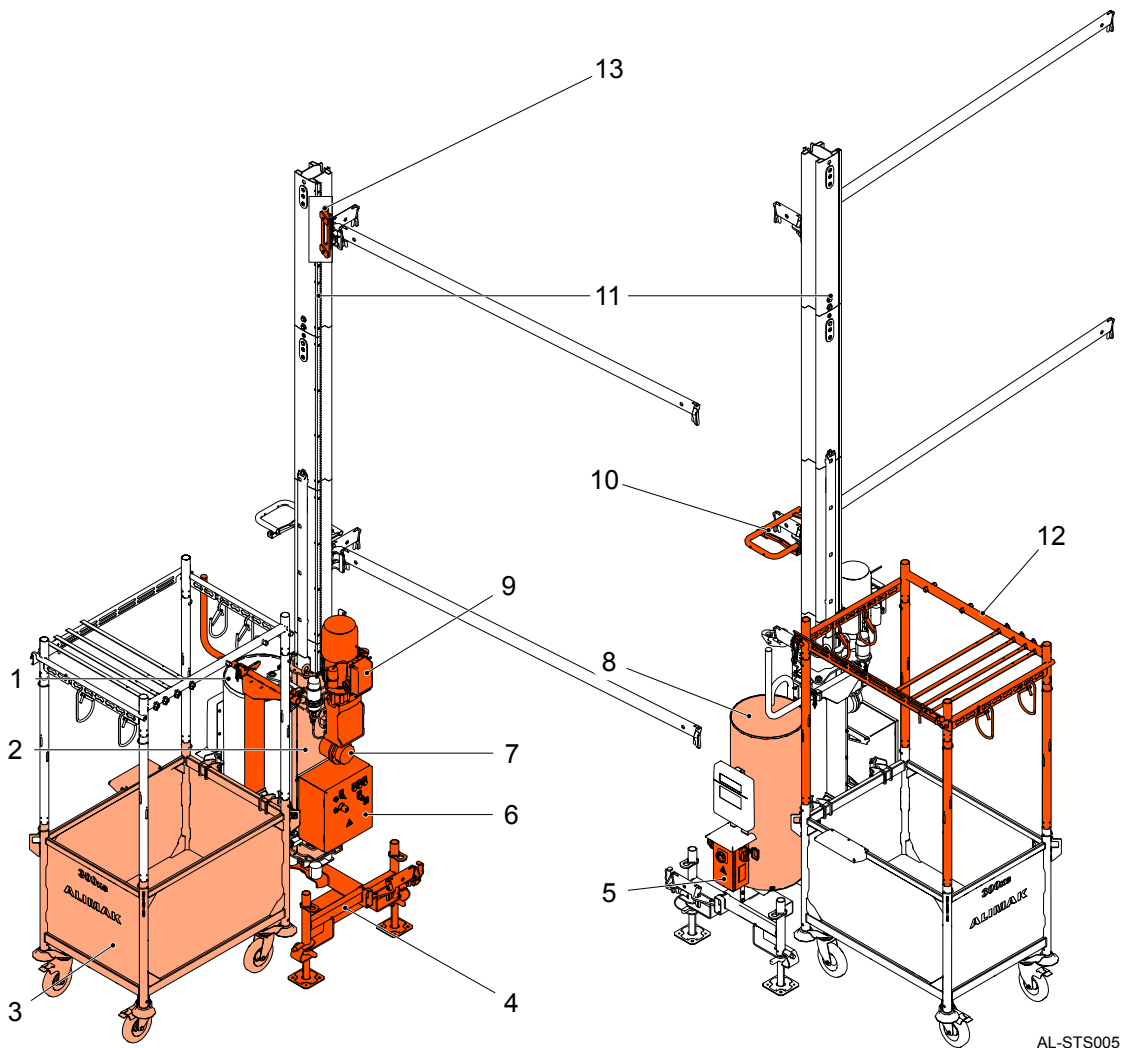

AL-ST5005

Figure 4 : Overview of the scaffolding transport system

Overview of the scaffolding transport system

1	Turning system	8	Cable collect bin
2	Drive unit	9	Drive system
3	Box	10	Cable guide
4	Base frame	11	Mast
5	Base frame control box	12	Upper frame of the box
6	Main control box	13	Anchor support
7	Overspeed safety device		

3.2 Scaffolding transport system parts

3.2.1 Base unit

EN-AL-06-01-0001-01

The base unit consists of the following main elements:

- Base frame
- Base frame control box
- Drive unit
- Turning system
- Anchoring system

3.2.1.1 Base frame

EN-AL-06-01-0004-01

The base frame may be equipped with 4 base plates¹⁾ whose height can be adjusted for positioning and levelling the scaffolding transport system.

The first mast section is installed on the base frame.

A level²⁾ installed on the rear part of the first mast section allows the horizontal and vertical levelling of the base frame to be checked.

The shock absorbers on the base frame act as bottom end stops in the event of a failure of the bottom limit and the emergency bottom limit switches.

The base frame is equipped with lifting points for transport, using the fork of a forklift.

The installation of the base unit lifting device at the top of the mast allows the base frame to be lifted and transported with a crane [Refer to section [Base unit lifting device](#), see on page 20].

Wheels and their adaptation to the base frame¹⁾ allow the base frame to be transported manually.

NOTICE



¹⁾ The adaptation for base frame wheels, the base frame wheels and the base plates are not supplied with the scaffolding transport system. If necessary, please contact the scaffolding manufacturer or Alimak for assistance.

NOTICE



²⁾ The level for checking the levelling of the base frame is not included in the scope of supply of the scaffolding transport system. Optionally, Alimak can supply the level for checking the levelling of the base frame.

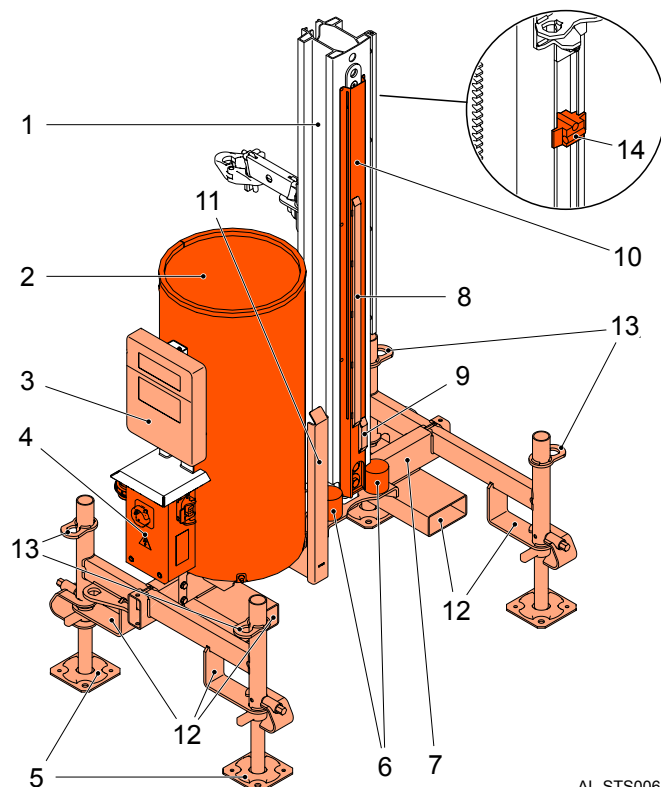

AL-ST5006

Figure 5 : Base frame

Base frame

1	First mast section
2	Cable collect bin
3	Document holder
4	Base frame control box
5	Adjustable base plates
6	Shock absorber
7	Base frame
8	Bottom limit cam
9	Emergency bottom limit cam
10	2 m cam
11	Box fastening system release cam
12	Lifting points for forklift fork
13	Anchor points for base frame wheel adaptation
14	Base frame level

3.2.1.2 Drive unit

EN-AL-06-01-0002-01

The drive unit consists of the following main elements:

- Drive system
- Overspeed safety device
- Guiding system
- Main control box
- Lubrication system

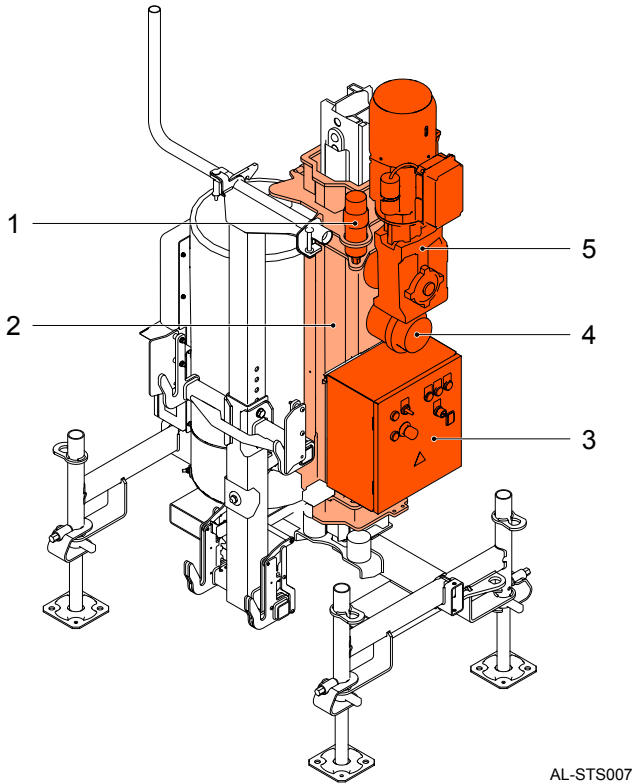

Figure 6 : Drive unit

Drive unit

- | | |
|---|-------------------------|
| 1 | Lubrication system |
| 2 | Guiding system |
| 3 | Main control box |
| 4 | Overspeed safety device |
| 5 | Drive system |

Drive system

The drive system allows the movement of the drive unit along the mast

The drive system motor is equipped with an electromagnetic brake. It stops the system when there is a stop command or in the event of a power failure.

The electromagnetic motor brake release lever allows the electromagnetic motor brake to be released manually for manual descent of the scaffolding transport system in the event of a power failure or in certain inspection and maintenance operations.

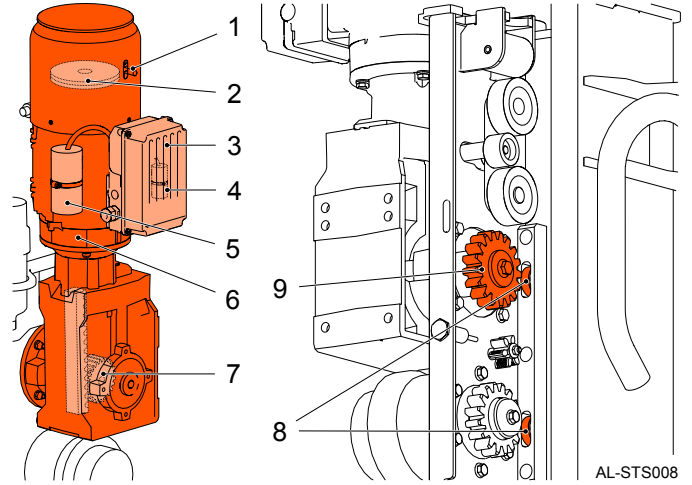

Figure 7 : Drive system

Drive system

- | | |
|---|-------------------------------------------|
| 1 | Electromagnetic motor brake release lever |
| 2 | Electromagnetic motor brake |
| 3 | Motor junction box |
| 4 | Start-up capacitor |
| 5 | Service capacitor |
| 6 | Motor |
| 7 | Gearbox |
| 8 | Drive system counter rollers |
| 9 | Drive pinion |

Overspeed safety device

The overspeed safety device is a mechanical device that stops the drive unit in the event of a drive system failure.

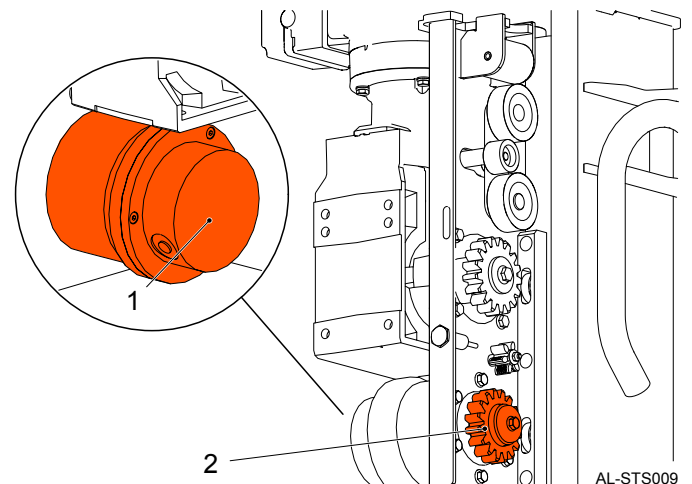

Figure 8 : Overspeed safety device

Overspeed safety device

- | | |
|---|--------------------------------|
| 1 | Overspeed safety device |
| 2 | Overspeed safety device pinion |

Guiding system

The guiding system ensures that the scaffolding transport system is correctly guided along its travel path.

The guide rollers roll along the mast.

The guide rollers are installed on the upper part and on the lower part of the drive unit.

A set of two rollers allows the pinions of the drive system and the overspeed safety device to engage correctly with the rack along the mast.

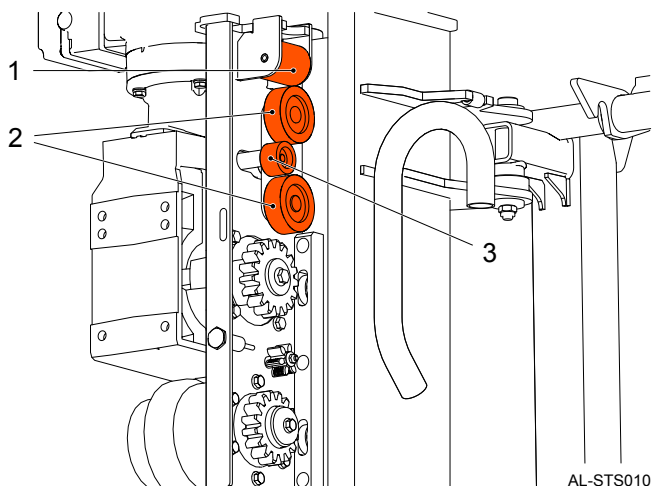

Figure 9 : Guiding system

Guiding system

- 1 Side rollers
- 2 Front rollers
- 3 Secondary front rollers

Main control box

Refer to section [Controls](#), see on page 16.

Base frame control box

Refer to section [Controls](#), see on page 16.

Lubrication system

The lubrication system allows lubricant to be distributed along the rack to prevent premature wear of the pinions and the rack and to ensure the correct operation of the drive system.

A lubricating pinion distributes lubricant along the rack.

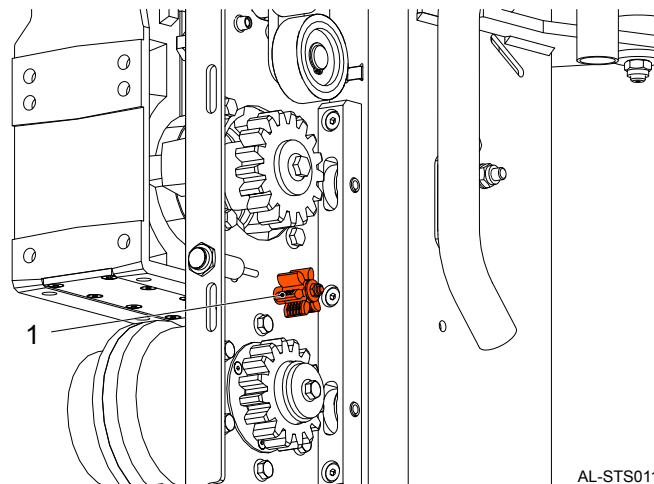

Figure 10 : Lubrication system

Lubrication system

- 1 Lubricating pinion

3.2.1.3 Turning system

EN-AL-06-01-0005-01

The turning system lever allows the user to turn the box for safer loading and unloading from the scaffolding. The box turns towards the scaffolding, reducing the distance between users and the load.

The overload detection device is integrated in the upper pivot point of the turning system.

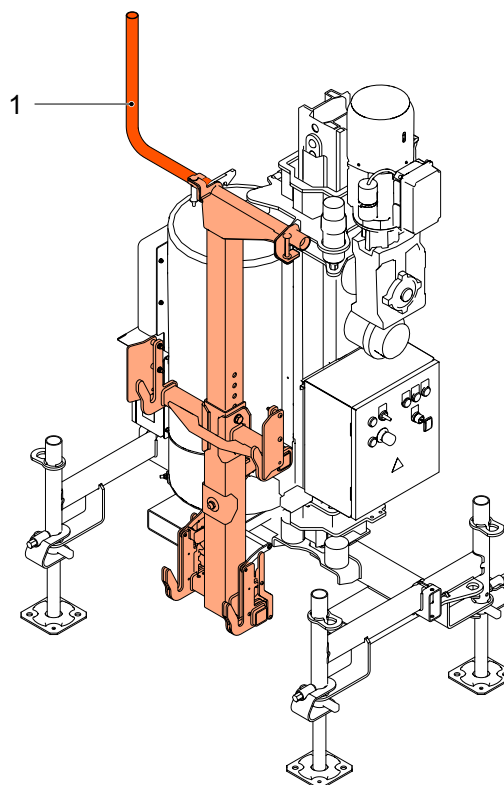

Figure 11 : Turning system

Turning system

- 1 Turning system lever

3.2.1.4 Anchoring system

EN-AL-06-01-0006-01

An anchoring system in the turning system allows the box to be coupled and secured to the drive unit [Refer to section [Coupling the box to the anchoring system](#), see on page 33].

The height of the anchoring system can be adjusted if necessary [Refer to section [Adjusting the height of the anchoring system](#), see on page 33].

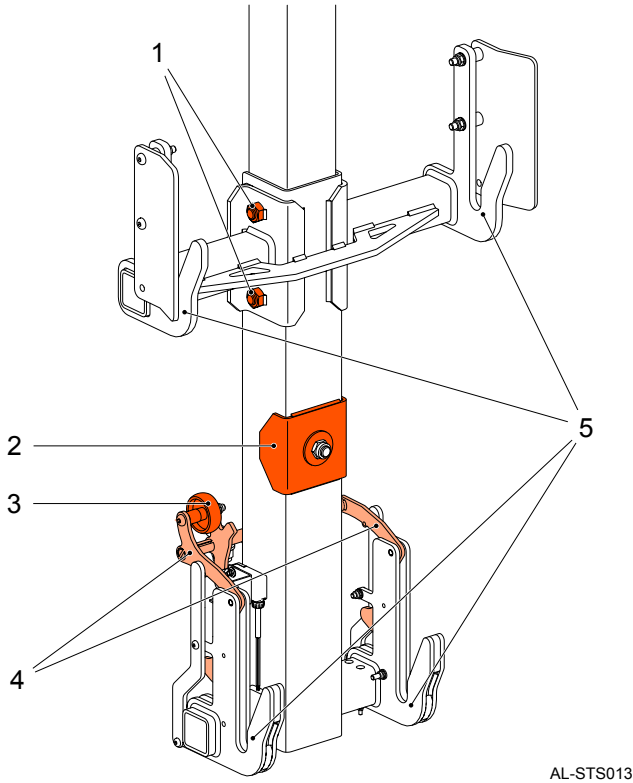

AL-STSO13

Figure 12 : Anchoring system

Anchoring system

- | | |
|---|------------------------------------|
| 1 | Height adjustment bolts |
| 2 | Anchoring system fixing plate |
| 3 | Box interlock system release wheel |
| 4 | Box fastening system |
| 5 | Box anchor points |

3.2.2 Mast

EN-AL-06-01-0007-01

The mast allows the drive unit to be guided along its travel path.

The connecting components between the sections that make up the mast allow correct alignment and transfer of loads.

The supports installed on the mast allow the ties to be fixed to the scaffolding and the cable guides.

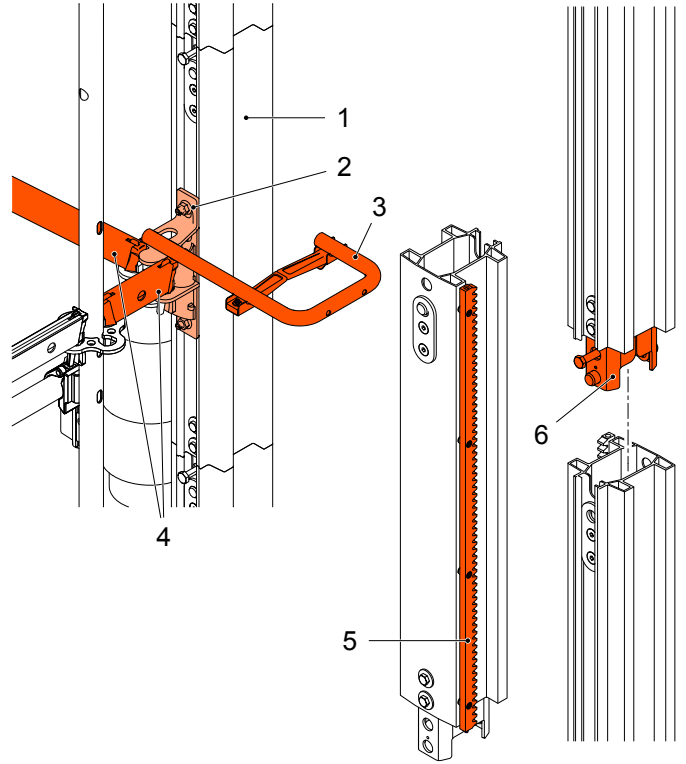

AL-STSO14

Figure 13 : Mast

Mast

- | | |
|---|------------------------|
| 1 | Mast |
| 2 | Anchor support |
| 3 | Cable guide |
| 4 | Ties ¹⁾ |
| 5 | Rack |
| 6 | Mast connection system |

NOTICE



¹⁾Ties are interface components that are not included in the scope of delivery of the scaffolding transport system.

3.2.3 Box

EN-AL-06-01-0008-01

The box allows the different scaffolding parts to be placed in a stable and secure way for transport to the required level.

The box accessories allow larger parts of the scaffolding to be transported.

An auxiliary box²⁾ allows the smallest parts of the scaffolding to be transported.

The box is equipped with lifting points that allow transport with a crane.

The box can be equipped with wheels that allow manual transport.

NOTICE



²⁾ The auxiliary box is not supplied with the scaffolding transport system.
Optionally, Alimak can supply the auxiliary box.

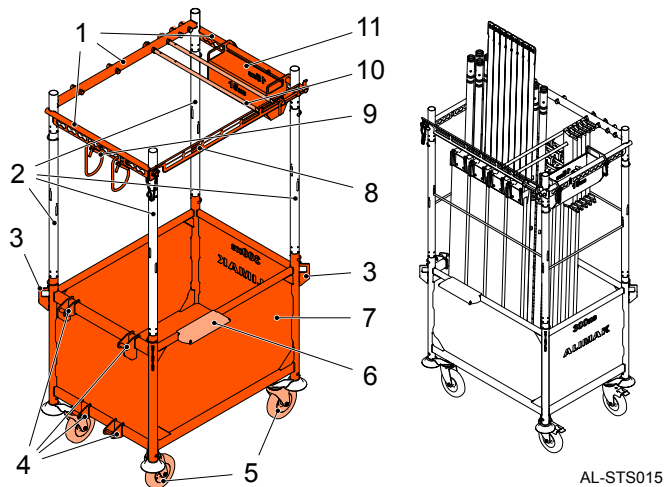

Figure 14 : Box

Box

- | | |
|----|---------------------------|
| 1 | Upper frame of the box |
| 2 | Vertical profiles |
| 3 | Lifting points |
| 4 | Anchor points |
| 5 | Wheels |
| 6 | Material support plate |
| 7 | Box |
| 8 | Upper frame front profile |
| 9 | Hooks |
| 10 | Removable bars |
| 11 | Auxiliary box |

3.3 Controls

3.3.1 Main control box

EN-AL-06-04-0004-01

The main control box is located in the drive unit.

The main control box has the following controls:

- UP button (box coupling mode)
- DOWN button (box coupling mode)
- Emergency-stop button

The main control box is equipped with lights which turn on in the following cases:

- Scaffolding transport system ready (green).
- Overload (red)
- Motor malfunction (red)

The main control box also has the following components:

- SERVICE selector (O / I)
- Mode of use selector (Transport mode / Box coupling mode)
- An acoustic buzzer warns in the event of overload or a downward movement of the scaffolding transport system in the 2 m safety zone.

The Mode of use selector in the box coupling mode position allows the scaffolding transport system to be controlled from the main control box and cancels the control from the user control station. The box coupling mode allows the up and down movement of the scaffolding transport system in the coupling and uncoupling area of the box to the anchoring system.

The Mode of use selector in the transport mode position allows the scaffolding transport system to be controlled from the user control station and cancels the control from the main control box. The transport mode allows the up and down movement of the scaffolding transport system in the transport area above the coupling and uncoupling area of the box to the anchoring system.

NOTICE



The box coupling mode controls have to remain pushed in order to function.

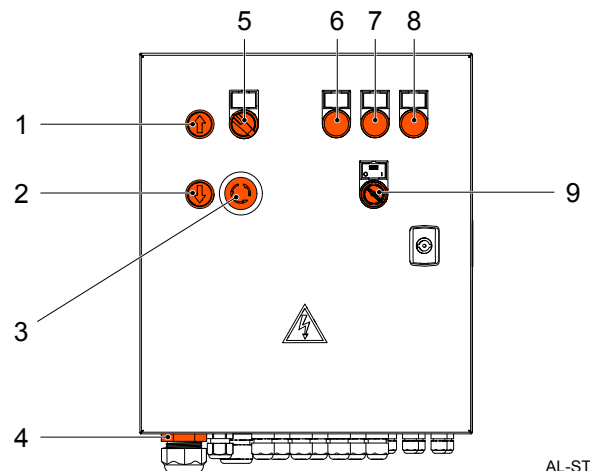

Figure 15 : Main control box

Main control box

- | | |
|---|-----------------------------------------------------------|
| 1 | UP button (box coupling mode) |
| 2 | DOWN button (box coupling mode) |
| 3 | Emergency-stop button |
| 4 | Warning buzzer |
| 5 | Mode of use selector (Transport mode / Box coupling mode) |
| 6 | Ready light (green) |
| 7 | Overload light (red) |
| 8 | Motor malfunction light (red) |
| 9 | SERVICE selector (O / I) |

3.3.2 Base frame control box

EN-AL-06-04-0005-01

The base frame control box is located on the base frame.

Connectors on the sides of the base frame control box allow the electrical power supply connector and the user control station to be connected.

The base frame control box is equipped with a main switch for disconnecting the power to the scaffolding transport system.

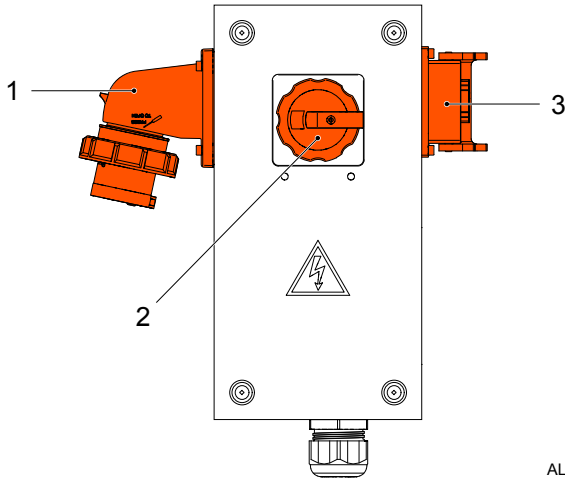

AL-ST017

Figure 16 : Base frame control box

Base frame control box

- | | |
|---|-----------------------------------|
| 1 | Electrical power supply connector |
| 2 | Main switch |
| 3 | User control station connector |

3.3.3 User control station

EN-AL-06-04-0006-01

The user control station allows control of the scaffolding transport system.

The user control station is equipped with a cable and a connector to connect it to the base frame control box, located on the base frame.

The user control station has the following controls:

- Emergency-stop button
- UP button
- DOWN button

NOTICE



The controls must be kept pressed down in order to work below the safety height of 2 m.

The controls require just one press once the 2 m safety height has been exceeded.

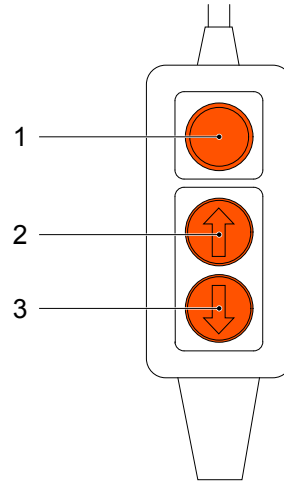

AL-ST018

Figure 17 : User control station

User control station

- | | |
|---|-----------------------|
| 1 | Emergency-stop button |
| 2 | UP button |
| 3 | DOWN button |

3.3.4 Free fall test control station

EN-AL-06-04-0007-01

The free fall test control station allows control of the scaffolding transport system for carrying out overspeed safety device verification tests.

The free fall test control station is equipped with a 10 m long cable and a connector to connect it to the main control box, located on the drive unit.

The connection for the free fall test control station is located inside the main control box.

The free fall test control station has the following controls:

- Overspeed safety device test button
- UP button

NOTICE



Only persons who have received the required familiarisation are authorised to perform the free fall test.

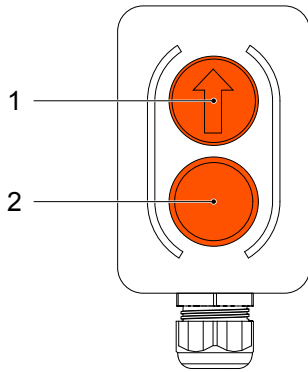

AL-STS018

Figure 18 : Free fall test control station

Free fall test control station

- | | |
|---|--------------------------------------------|
| 1 | Free fall test control station UP button |
| 2 | Free fall test control station TEST button |

3.4 Safety devices

3.4.1 Bottom limit switch

EN-AL-06-05-0001-01

The bottom limit switch stops the scaffolding transport system from descending when it comes into contact with the bottom limit cam located on the first mast.

The ascent of the scaffolding transport system is possible if the bottom limit switch is activated.

3.4.2 Emergency bottom limit switch

EN-AL-06-05-0003-01

The emergency bottom limit switch stops the scaffolding transport system from descending when it comes into contact with the emergency bottom limit cam located on the first mast in the event of a failure of the bottom limit switch.

The ascent of the transport system is possible if the Mode of use selector is in the box coupling mode [Refer to section [Main control box](#), see on page 16].

3.4.3 Level sensor

EN-AL-06-05-0004-01

The level sensor stops the scaffolding transport system from ascending or descending by detecting the level detection cam located on the anchor system support.

NOTICE



The level sensor requires the UP or DOWN button on the user control station to be kept pressed in order for it to be activated above the 2 m safety height.

3.4.4 Top limit sensor

EN-AL-06-02-0003-01

The top limit sensor stops the scaffolding transport system from ascending if it is deactivated due to the mast not being detected after exceeding the upper end of the last section installed.

The descent of the scaffolding transport system is possible if the top limit sensor is deactivated.

3.4.5 Emergency top limit sensor

EN-AL-06-05-0006-01

The emergency top limit sensor stops the scaffolding transport system from ascending if it is deactivated due to the mast not being detected after exceeding the upper end of the last section installed in the event of a failure of the top limit sensor.

The emergency top limit sensor interrupts the control of the scaffolding transport system.

3.4.6 2 m zone switch

EN-AL-06-05-0007-01

The 2 m zone switch stops the scaffolding transport system from ascending and descending when the safety height of 2 m is reached.

An acoustic buzzer on the main control box indicates the downwards movement of the scaffolding transport system in the travel path section between 2 m high and the base.

NOTICE



The controls must be kept pressed down in order to work below the safety height of 2 m.

3.4.7 Box detection switch

EN-AL-06-02-0004-01

The box detection switch interrupts the control of the scaffold transport system if the box is not detected at the anchor points.

NOTICE



The box detection switch system switch can be controlled if the Mode of use selector is in the transport mode position.

3.4.8 Overload detection device

EN-AL-06-06-0005-01

Consisting of the load cell integrated in the upper pivot point of the swivelling system and the overload control unit located inside the main control box, it prevents the scaffolding transport system from ascending and descending in the event of an overload.

If an overload is detected, the control of the scaffolding transport system is interrupted.

A light and an acoustic buzzer on the main control box indicate the overload.

DANGER



Risk of accident. Performing a manual descent in case of overload is prohibited.

3.4.9 Box rotation switch

EN-AL-06-06-0006-01

The box rotation switch interrupts the control of the scaffolding transport system by turning the box to load or unload materials on one level of the scaffolding.

3.4.10 Overspeed safety device switch

EN-AL-06-06-0007-01

The overspeed safety device switch interrupts the control of the scaffolding transport system if the overspeed safety device is activated.

3.4.11 Box fastening system switch

EN-AL-06-06-0009-01

The box fastening system switch interrupts the scaffolding transport system control if the correct box fastening is not detected.

NOTICE



The box fastening system switch can be controlled if the Mode of use selector is in the transport mode position.

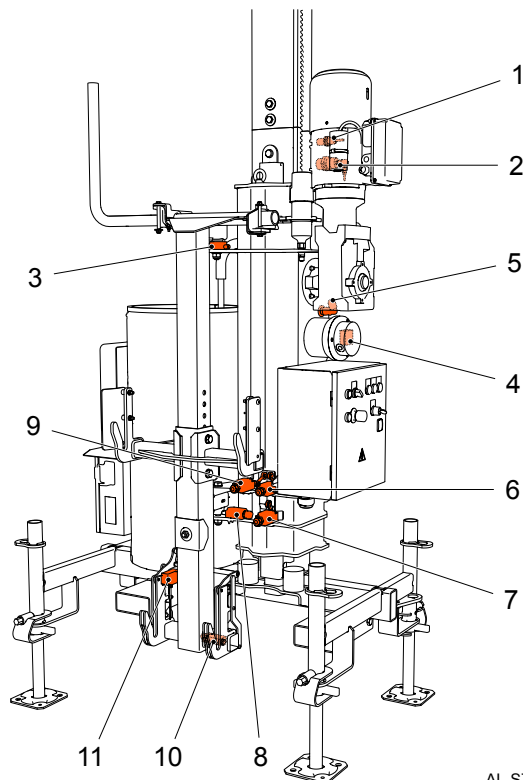

AL-STSO20

Figure 19 : Safety devices

Safety devices

- | | |
|----|--------------------------------|
| 1 | Top limit sensor |
| 2 | Emergency top limit sensor |
| 3 | Load cell |
| 4 | Overspeed safety device switch |
| 5 | Level sensor |
| 6 | 2 m zone switch |
| 7 | Emergency bottom limit switch |
| 8 | Turning system switch |
| 9 | Bottom limit switch |
| 10 | Box detection switch |
| 11 | Box fastening system switch |

3.4.12 Acoustic buzzer

EN-AL-06-06-0008-01

The acoustic buzzer emits a warning sound in the following cases:

- During the descent of the scaffolding transport system on the travel path section between the base and 2 m high. (continuous sound).
- Overload of the scaffolding transport system (intermittent sound).

The acoustic buzzer is located in the main control box.

3.5 Guided trailing cable management system

EN-AL-06-07-0001-01

In the guided trailing cable management system the drive unit pulls the cable during ascent uncoiling it from a cable collect bin.

The cable guides are installed on the mast along the travel path to reduce cable movement.

The force of gravity coils the cable back into the cable collect bin while the drive unit is descending.

The cable is stored in a cable collect bin while the scaffolding transport system is not in operation.

The cable hangs from the drive unit by means of a cable bracket.

The cable collect bin is located on the base frame.

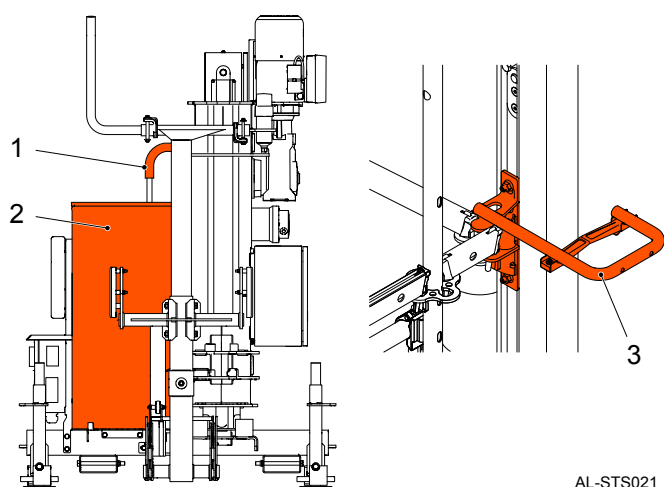

AL-STS021

Figure 20 : Guided trailing cable management system

Guided trailing cable management system

- | | |
|---|-------------------|
| 1 | Cable bracket |
| 2 | Cable collect bin |
| 3 | Cable guide |

3.6 Base unit lifting device

EN-AL-06-08-0001-01

The base unit lifting device is a device that is installed in the upper part of the mast, allowing the base unit to be lifted and transported with a crane.

- Installation of the base unit lifting device:
 1. Insert the lifting device into the first mast section on the base unit.
 2. Tighten the fastening bolt to a tightening torque of 40 N·m.
 3. Check that the connector locking pins are positioned correctly in the holes on the first mast section.

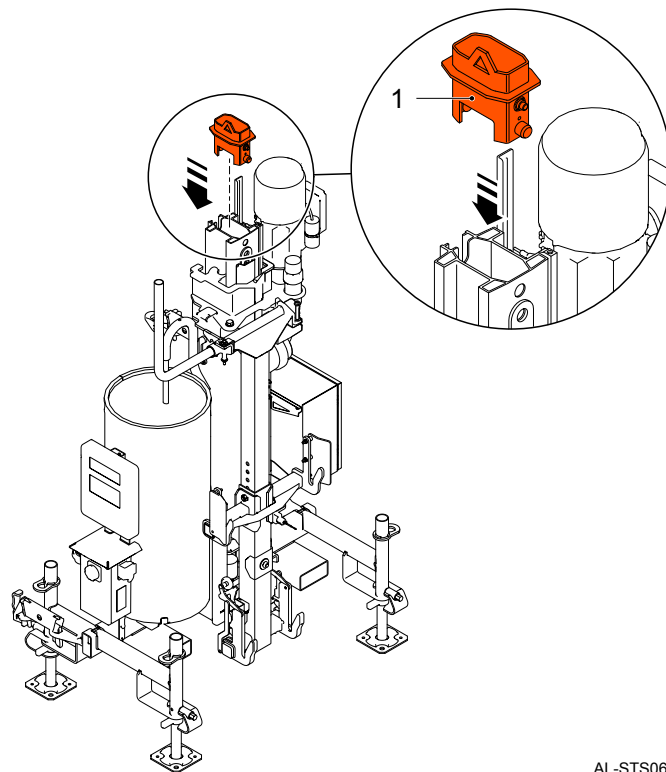

AL-STS061

Figure 21 : Base unit lifting device

Base unit lifting device

- | | |
|---|--------------------------|
| 1 | Base unit lifting device |
|---|--------------------------|

4 Transport

4.1 General transport requirements

EN-AL-08-01-0001-01

Carry out the transport in a suitable vehicle in accordance with the size and weight characteristics of the scaffolding transport system [Refer to section *Technical specifications*, see on page 6].

NOTICE



Carry out the transport with the box uncoupled from the anchoring system.

NOTICE



Disassemble and stack the boxes for transport.

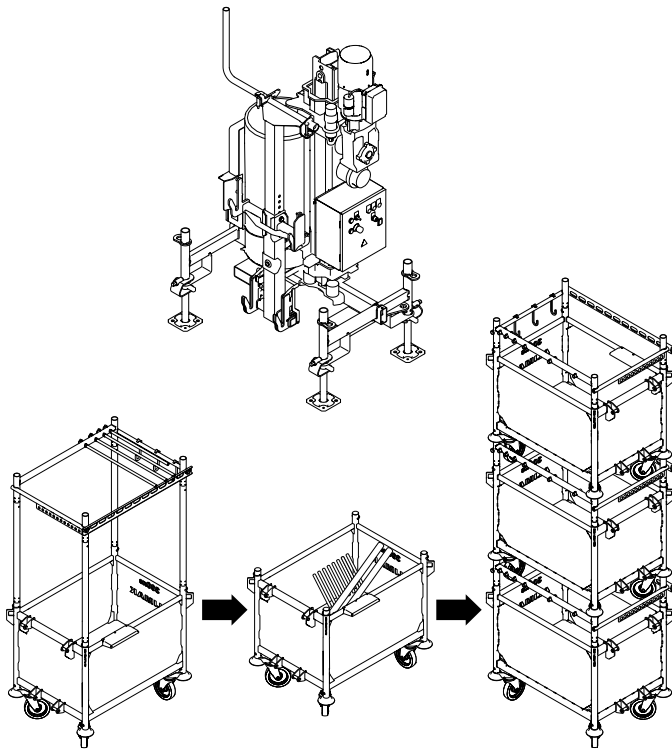

AL-STS022

Figure 22 : Transporting the STS 300 scaffolding transport system

4.2 Delivery inspection

EN-AL-10-13-0001-01

Check that the materials delivered correspond with those specified in the order and that they are in good state. In case of damage to the goods caused during transport, inform the company in charge of transport management within 24 hours following the date of delivery.

For any other type of claim, please contact Alimak within 24 hours of the delivery date.

5 Installation, use and inspection

5.1 Installation and usage requirements

5.1.1 Soil compression

EN-AL-10-14-0002-01

Before installing the scaffolding transport system, check that the ground on which the base frame is located has the capacity to withstand the forces generated.

If necessary, use plates on the ground to distribute the load [Refer to figure [Support point base dimensions](#), see on page 22].

Installation height (m)	Total weight (kg)	Maximum force per support point (kg)
9.5	1160	430
19.5	1330	485
29.5	1490	540
39.5	1660	590
49.5	1820	645

NOTICE

i The detailed list of scaffolding transport system installation requirements is available at Alimak upon request.

NOTICE

i Depending on the local regulations, an approval of the installation by a third party may be necessary.

5.2 Electrical power supply

EN-AL-10-03-0000-01

The electrical power supply characteristics for the scaffolding transport system must be in accordance with the specifications in the table below.

Electrical power supply requirements	
Electrical power supply	Requirements
230 V 50 Hz	1 Phase + N + PE

A power supply point with a voltage of 230 V/50 Hz must be used in the installation, with a differential switch to protect people and a 16 A Class C switch (to protect against overloads and short circuits).

Use a 3G4 flexible cable with rubber insulation of 3 x 4 mm² and a maximum length of 30 m. Optionally, use a 3G6 flexible cable with rubber insulation of 3x6mm² in length and a maximum length of 50m¹⁾.

Connect the cable directly to the site's electrical power supply point to avoid any voltage drop and consequently a loss of power to the motor.

The grounding and protection against atmospheric discharges system must be in accordance with the applicable local regulations.

NOTICE

i ¹⁾The flexible cable is not supplied with the scaffolding transport system. Optionally, Alimak can supply a 50 m long 3G6 flexible cable upon request.

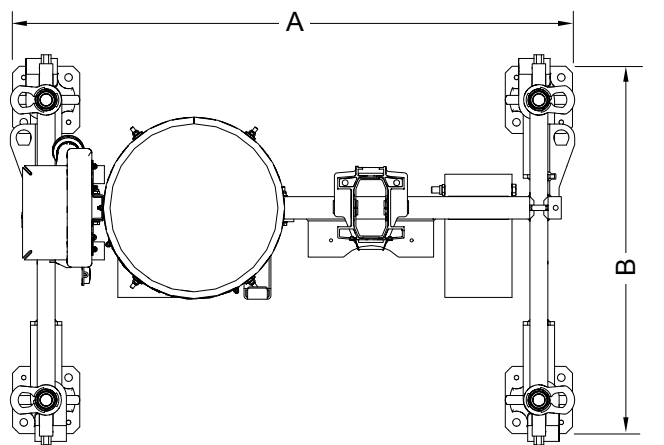

AL-STS023

Figure 23 : Support point base dimensions

Support point base dimensions

A	125 cm
B	60 cm

5.3 Installation and levelling of the base unit

EN-AL-10-11-0001-01

The installation of the first mast sections for the installation and levelling of the base unit must be in accordance with the specifications in the table below.

Fig.	Height difference (cm)			Type of installation STS	No. of sections: M1 (330 mm)	No. of sections: M2 (1005 mm)	J (cm)	K (cm)
a	0	-	25.5	Type 1	0	1	a	47.5-49.5
b	0	-	35.5		0	1	b	
	35.6	-	50.5	1	1	b-34		
c	50.6	-	68.5	1	1	c-34		
	68.6	-	75.5	2	1	c-67		
d	50.6	-	68.5	1	1	d-34		
	68.6	-	100.5	2	1	d-67		
e	100.6	-	125.5	0	2	e-101.5		
f	100.6	-	136	0	2	f-101.5		
	136.1	-	150.5	1	2	f-134.5		
g	150.6	-	169	1	2	g-134.5		
	169.1	-	175.5	2	2	g-167.5		
h	150.6	-	169	1	2	h-134.5		
	169.1	-	200.5	2	2	h-167.5		

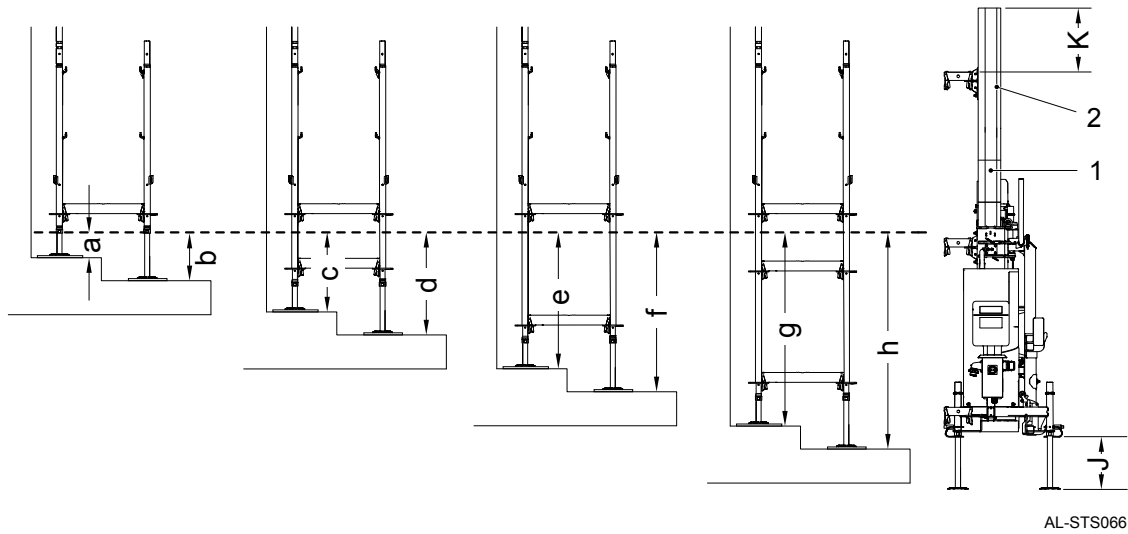

Figure 24 : Installation of the first mast sections

Installation of the first mast sections

- 1 Mast section M1 (330 mm)
- 2 Mast section M2 (1005 mm)

NOTICE



¹⁾ Depending on the height of the first scaffolding platform, install the first mast sections specified in the table. [Refer to table [Installation of the first mast sections](#), see on page 23].

5.3.1 Type 1 installation

EN-AL-10-11-0002-01

1. Position the base frame at a distance of 32.3 cm from the scaffolding, ensuring that the mast is aligned with the vertical profile of the scaffolding.
2. Remove the lifting device or the wheels and their adaptation if used previously in order to position the base frame.
3. Adjust the four adjustable base plates on the base frame until the assembly height is reached and the mast is level [Refer to dimension B in table *Installation of the first mast sections*, see on page 23].
4. Fix the four adjustable base plates on the base frame.
5. Anchor the base frame to the two anchor points on the scaffolding base.
6. Install the anchor bracket on the first mast section [Refer to section *Anchor support*, see on page 28].
7. Anchor the first mast section to the scaffolding.
8. Install the next mast section [Refer to table *Installation of the first mast sections*, see on page 23 and section *Connection of the mast sections*, see on page 28].
9. Install the anchor bracket on the mast [Refer to section *Anchor support*, see on page 28].
10. Anchor the mast section to the scaffolding [Refer to section *Connecting the mast to the scaffolding*, see on page 28].
11. Check that the distance between the top of the mast section and the top of the anchor is between 47.5 cm and 49.5 cm [Refer to figure *Installation of the first mast sections*, see on page 23].
12. Install the cable guide [Refer to section *Cable guide*, see on page 29].
13. Slide the 2 m zone switch activation cam upwards and fix it in place.
14. Repeat the process described above from stage 8 to stage 11.

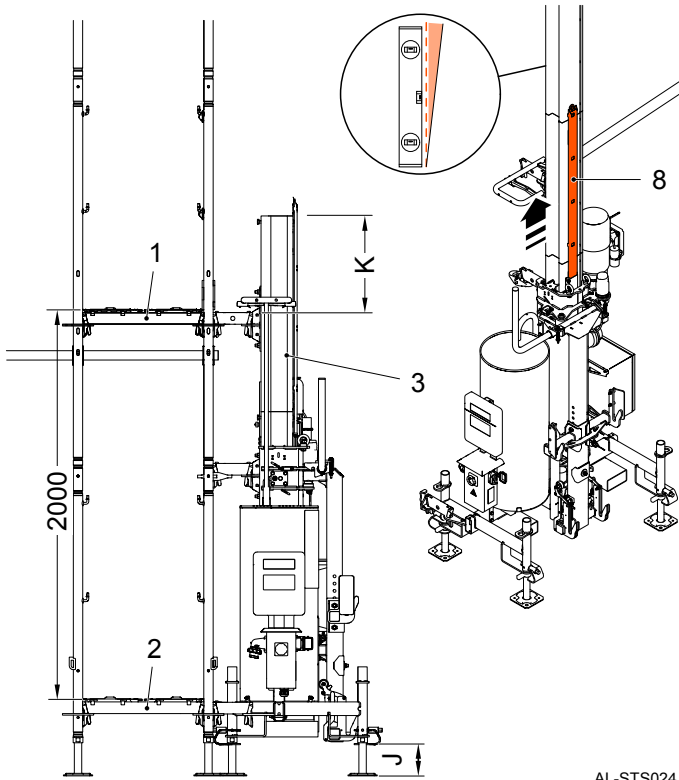

AL-STS024

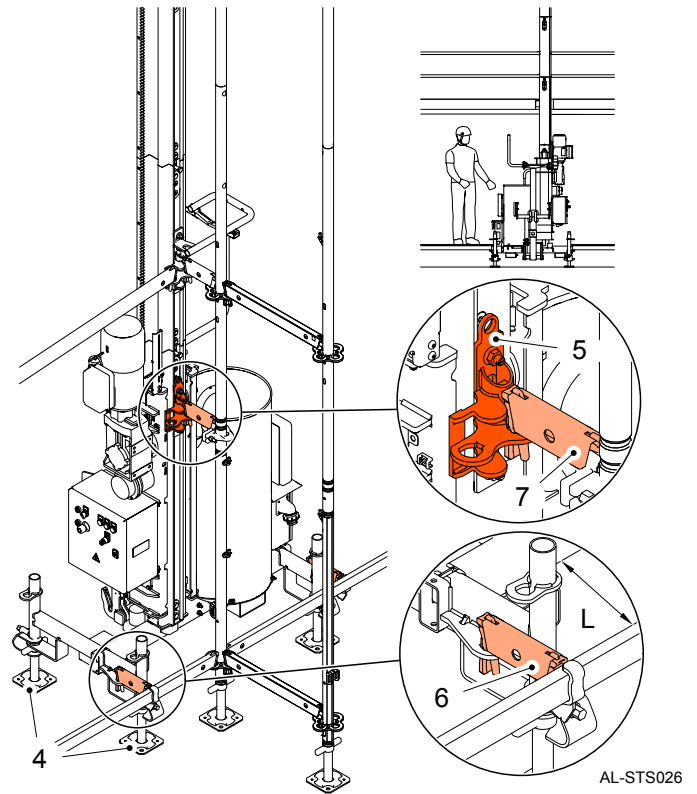

AL-STS026

Figure 25 : Installation and levelling of the base unit (Type 1)

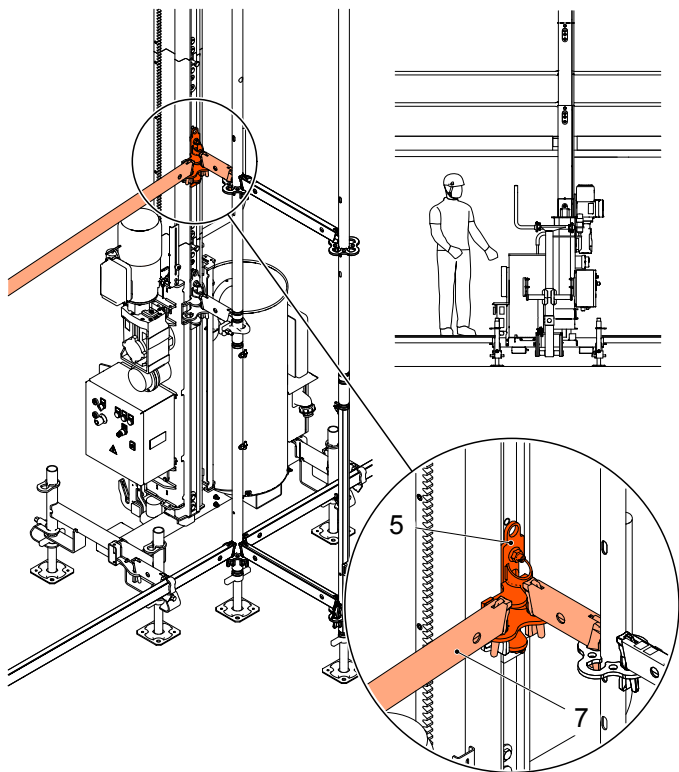

AL-STS025

Installation and levelling of the base unit (Type 1)

- 1 First scaffolding platform
 - 2 Bottom scaffolding platform
 - 3 Mast section M2 (1005 mm)¹⁾
 - 4 Adjustable base plates
 - 5 Anchor support
 - 6 Base frame anchors
 - 7 Anchors
 - 8 2 m cam
- J 1)
- K min. 47.5 cm - max. 49.5 cm ¹⁾
- L max. 32.3 cm

NOTICE



¹⁾Refer to table *Installation of the first mast sections*, see on page 23.

5.3.2 Type 2 installation

EN-AL-10-11-0004-01

1. Position the base frame at a distance of 32.3 cm from the scaffolding, ensuring that the mast is aligned with the vertical profile of the scaffolding.
2. Remove the lifting device or the wheels and their adaptation if used previously in order to position the base frame.
3. Adjust the four adjustable base plates on the base frame until the assembly height is reached and the mast is level [Refer to dimension B in table *Installation of the first mast sections*, see on page 23].
4. Fix the four adjustable base plates on the base frame.
5. Anchor the base frame to the two anchor points on the scaffolding base¹⁾.
6. Install the anchor bracket on the first mast section [Refer to section *Anchor support*, see on page 28].
7. Anchor the first mast section to the scaffolding.
8. Install the next mast sections²⁾ [Refer to table *Installation of the first mast sections*, see on page 23 and section *Connection of the mast sections*, see on page 28].
9. Install the anchor bracket on the mast [Refer to section *Anchor support*, see on page 28].
10. Anchor the mast section to the scaffolding [Refer to section *Connecting the mast to the scaffolding*, see on page 28].
11. Check that the distance between the top of the mast section and the top of the anchor is between 47.5 cm and 49.5 cm [Refer to figure *Installation of the first mast sections*, see on page 23].
12. Install the cable guide [Refer to section *Cable guide*, see on page 29].
13. Slide the 2 m zone switch activation cam upwards and fix it in place.
14. Repeat the process described above from stage 8 to stage 11.

NOTICE



¹⁾If it is not possible to anchor the base frame to the scaffolding base, the first mast section installed on the base frame must be anchored to the scaffolding.

NOTICE



²⁾In case of installing mast sections of different lengths, first install the M1 sections (330 mm) and then the M2 sections (1005 mm).

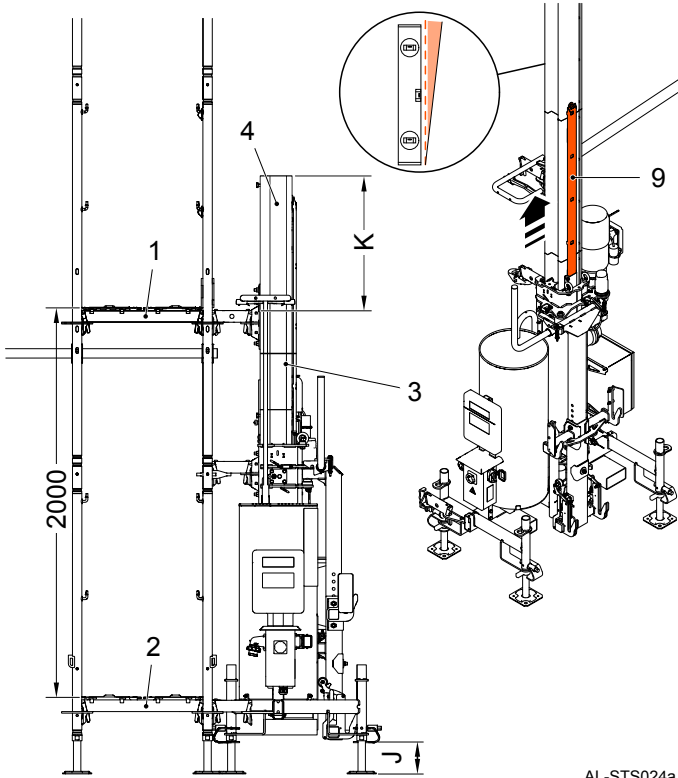

AL-STS024a

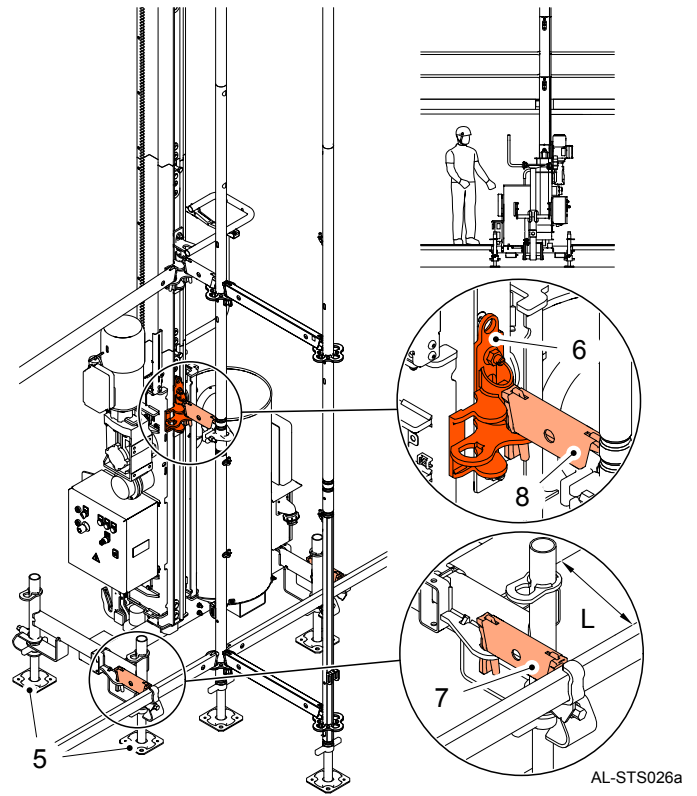

AL-STS026a

Figure 26 : Installation and levelling of the base unit (Type 2)

Installation and levelling of the base unit (Type 2)

- 1 First scaffolding platform
- 2 Bottom scaffolding platform
- 3 Mast section M1(330 mm)¹⁾
- 4 Mast section M2 (1005 mm)¹⁾
- 5 Adjustable base plates
- 6 Anchor support
- 7 Base frame anchors
- 8 Anchors
- 9 2 m cam
- J 1)
- K min. 47.5 cm - max. 49.5 cm ¹⁾
- L max. 32.3 cm

NOTICE



¹⁾Refer to table *Installation of the first mast sections*, see on page 23.

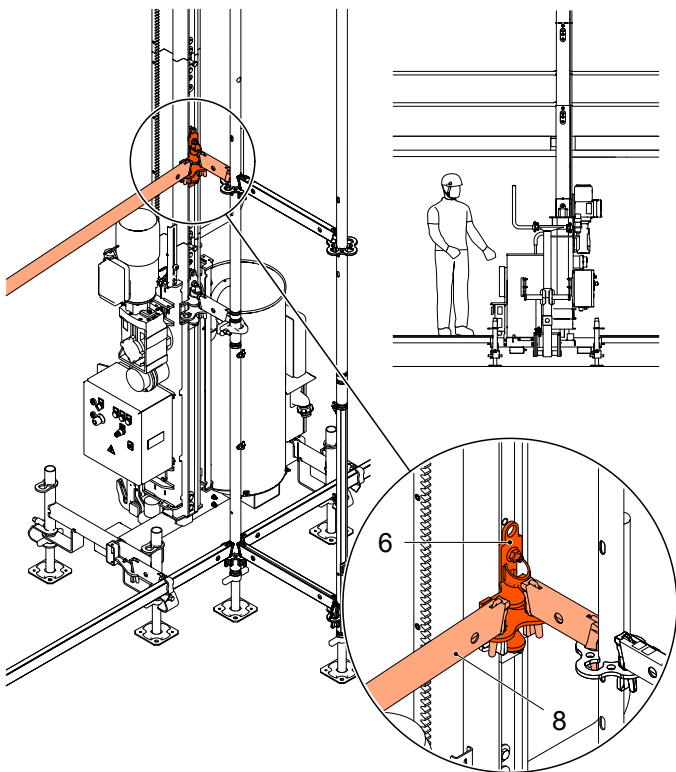

AL-STS025a

5.4 Installation of the mast

5.4.1 Connection of the mast sections

EN-AL-10-15-0001-01

1. Insert the upper mast section connector into the lower section.
2. Check that the connector locking pins are positioned correctly in the holes on the lower mast section.
3. Tighten the fastening bolt to a tightening torque of 40 N·m.

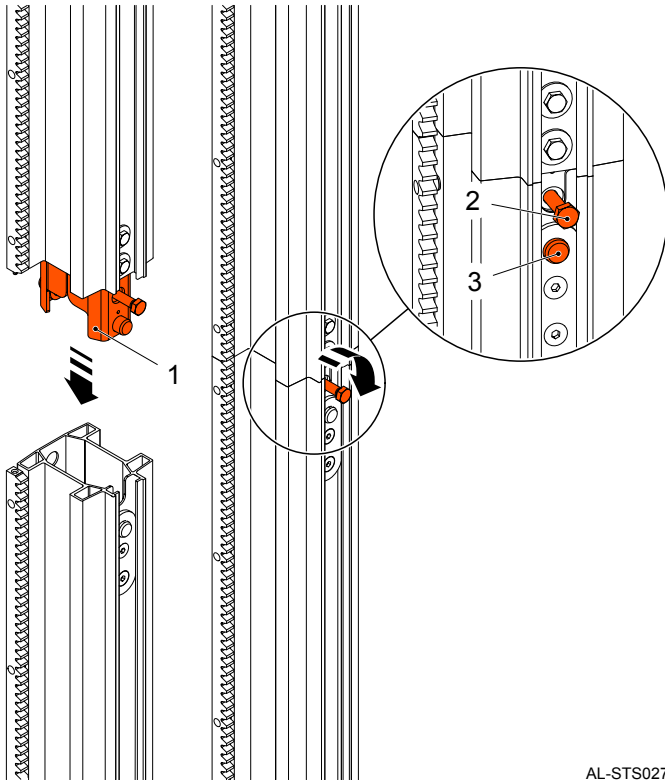

AL-STS027

Figure 27 : Connection of the mast sections

Connection of the mast sections

- | | |
|---|----------------|
| 1 | Connector |
| 2 | Fastening bolt |
| 3 | Locking pin |

5.4.2 Anchor support

EN-AL-10-15-0002-01

WARNING



Risk of breakage. The maximum distance between anchor brackets must be 2 m.

1. Insert the fixing plates into the mast slot and position the anchor bracket at the height of the rosette on the scaffolding.
2. Tighten the fastening nuts to a tightening torque of 40 N·m.
3. Check that the fixing plates are correctly positioned in the mast slot.

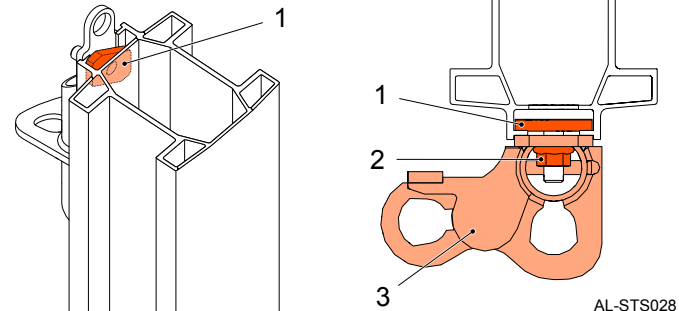
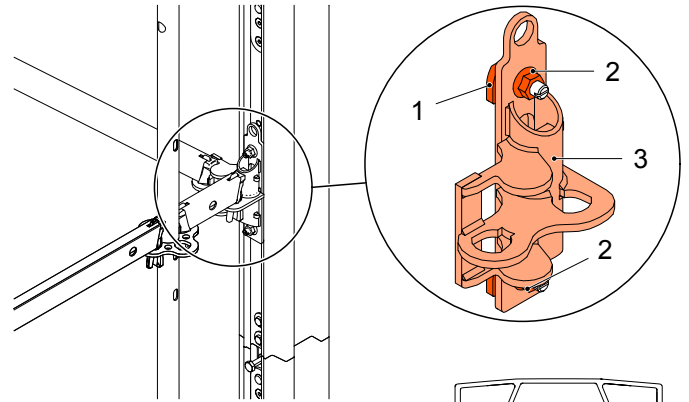

AL-STS028

Figure 28 : Anchor support

Anchor support

- | | |
|---|----------------|
| 1 | Fixing plate |
| 2 | Fastening nut |
| 3 | Anchor support |

5.4.3 Connecting the mast to the scaffolding

EN-AL-10-15-0004-01

WARNING



Risk of breakage. The maximum distance between tie brackets must be 2 m.

1. Check that the mast is vertically level and aligned with the vertical profile of the scaffolding.
2. Fix one end of the perpendicular tie in the central position of the tie bracket and the other end to the scaffolding.
3. Fix one end of the angled anchor in the side position of the anchor bracket and the other end to the scaffolding.

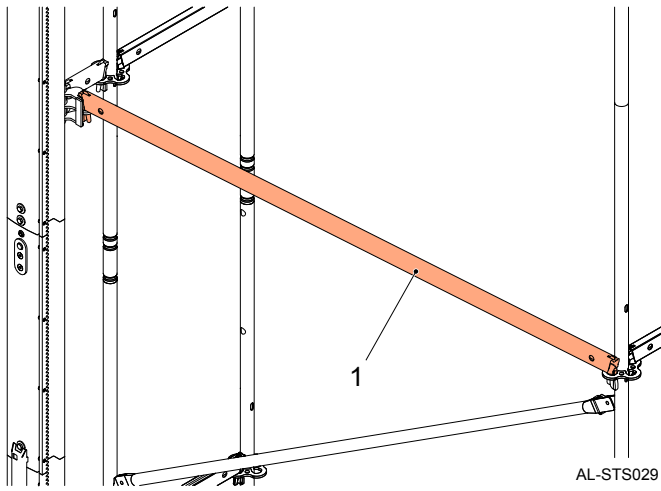

Figure 29 : Angled anchor

Angled anchor

- 1 | Angled anchor

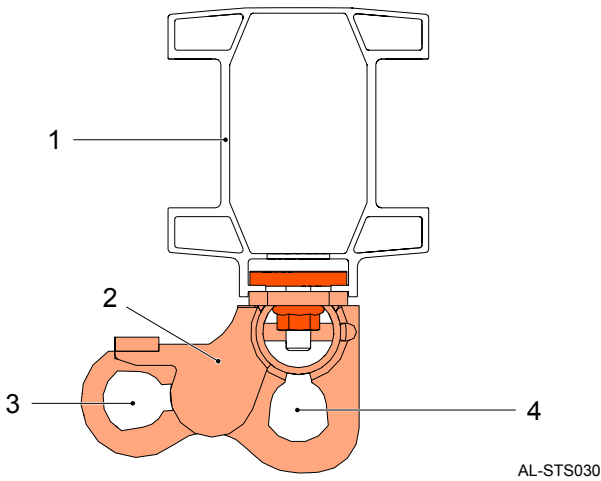

Figure 30 : Anchor support

Anchor support

- 1 | Mast
- 2 | Anchor support
- 3 | Side position of the tie bracket
- 4 | Central position of the tie bracket

5.4.4 Cable guide

EN-AL-10-15-0005-01

1. Insert the fixing plates into the mast slot and position the cable guide just above the anchor bracket¹⁾.
2. Tighten the fastening nut to a tightening torque of 40 N·m.
3. Check that the fixing plate is correctly positioned in the mast slot.

NOTICE



¹⁾The distance between cable guides must be 6 m and they must not interfere with the turning area of the box.
The first cable guide must be installed above the anchor bracket installed in the second mast section.

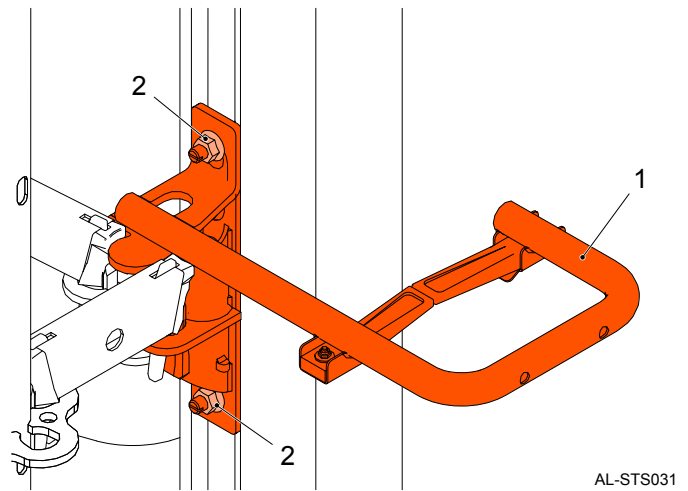

Figure 31 : Cable guide

Cable guide

- 1 | Cable guide
- 2 | Fastening nut

5.4.5 Dimensions

EN-AL-10-15-0006-01

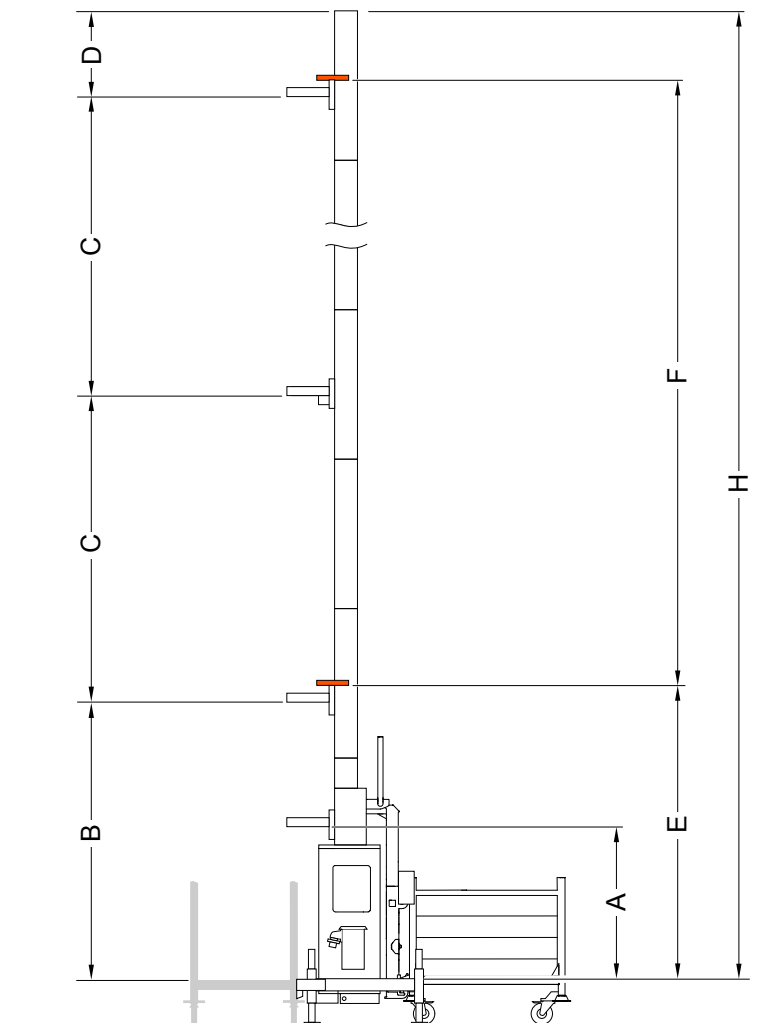

AL-STS032

Figure 32 : Dimensions

Dimensions

A	Height of first anchor 1.1 m
B	Height of second anchor 2 m
C	Distance between anchors 2 m
D	Max. height permitted without anchor 1 m
E	Height of first cable guide 2 m
F	Distance between cable guides 6 m
H	Max. height 50 m

5.4.6 Forces on the anchors

5.4.6.1 Forces on the anchors in working conditions

EN-AL-10-15-0007-01

Assembly conditions		
Distance between anchors	Max. permitted height without anchors	Width of the scaffolding
2 m	1 m	2 m - 2.5 m - 3 m

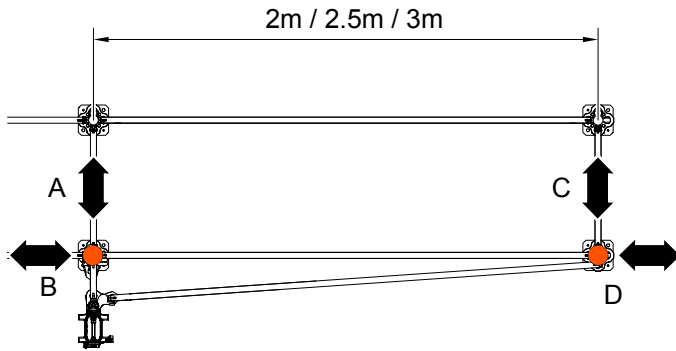

AL-STSO33

Figure 33 : Forces on the anchors

Forces on the anchors

A	$F_{x1}: \pm 4.0 \text{ kN}$
B	$F_{y1}: \pm 2.0 \text{ kN}$
C	$F_{x2}: \pm 1.0 \text{ kN}$
D	$F_{y2}: \pm 4.0 \text{ kN}$

5.4.6.2 Forces on the anchors when the scaffolding transport system is out of service

EN-AL-10-15-0008-01

The forces on the anchors when the scaffolding transport system is out of service are less than in working conditions.

Use of the scaffolding transport system with a maximum height of 50 m is authorised in regions A / B, C and D, in accordance with the Wind Region Map (Europe) as outlined in standard EN 12158-1:2000 Annex A.

NOTICE



The company in charge of the installation is responsible for applying the correct wind region. Local environmental conditions can cause deviations and make it necessary to apply a different wind region.

NOTICE



Please contact Alimak in the event of using the scaffolding transport system outside of the areas in which it is authorised.

5.5 Electrical connections

EN-AL-10-03-0001-01

1. Connect the electrical power supply connector for the scaffolding transport system to the base frame control box.
2. Connect the user control station connector to the base frame control box.

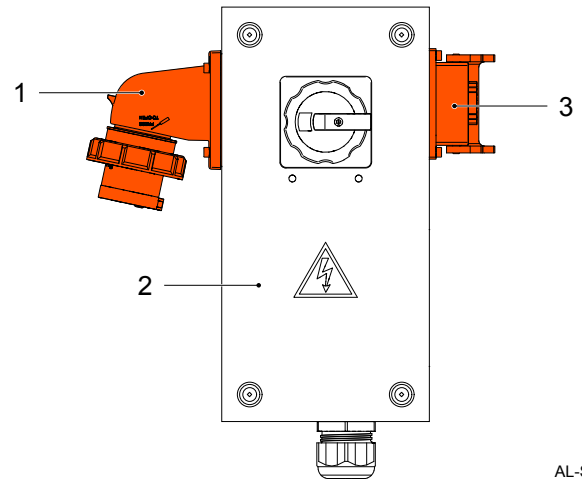

AL-STSO34

Figure 34 : Electrical connections

Electrical connections

- | | |
|---|-----------------------------------|
| 1 | Electrical power supply connector |
| 2 | Base frame control box |
| 3 | User control station connector |

5.6 Installation of the box

5.6.1 Assembly of the box

EN-AL-10-17-0001-01

1. Install the four vertical profiles on the corners of the upper frame of the box.
2. Fit the cotter pins.
3. Install the four vertical profiles together with the upper frame of the box on the corners of the box.
4. Fit the cotter pins.
5. Install the material support plate on the box.

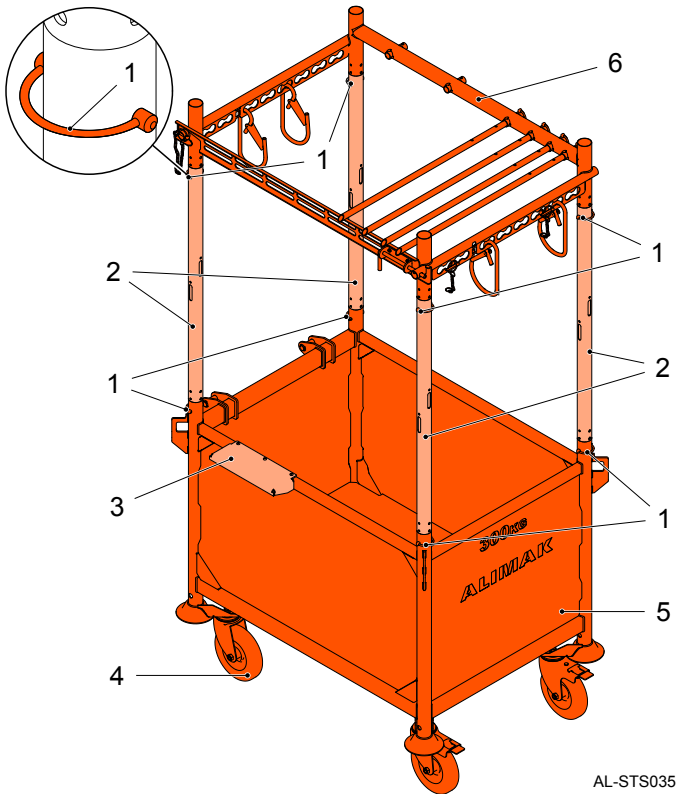

AL-STS035

Figure 35 : Box

Box

- | | |
|---|------------------------|
| 1 | Cotter pin |
| 2 | Vertical profiles |
| 3 | Material support plate |
| 4 | Wheels |
| 5 | Box |
| 6 | Upper frame of the box |

5.6.2 Assembly of the box wheels

EN-AL-10-17-0007-01

The box age is designed so that two different types of wheel can be installed¹⁾:

- Wheels installed on the box wheel brackets:
 1. Position the wheel on the lower part of the bracket.
 2. Fit the fixing bolt, nut and washer.
 3. Tighten the fastening nut.
- Wheels installed on the box feet:
 1. Insert the wheel into the tube of the box foot.
 2. Fit the cotter pin.

NOTICE



¹⁾The wheels to be installed on the box are not included in the scope of supply of the scaffolding transport system. Optionally, Alimak can supply the wheels to install on the box wheel brackets.

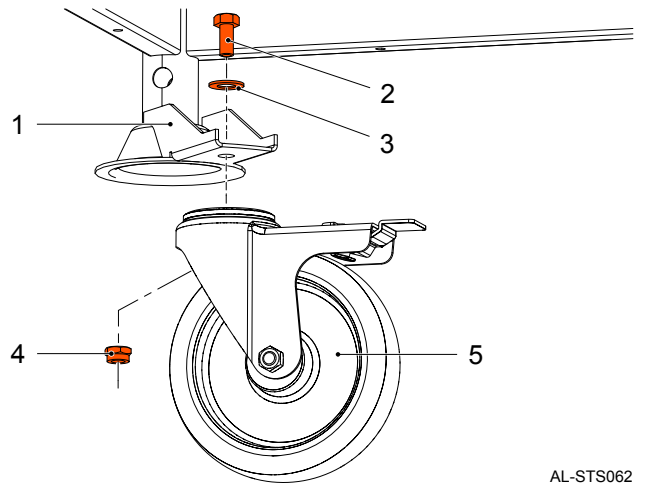

AL-STS062

Figure 36 : Wheels installed on the box wheel brackets

Wheels installed on the box wheel brackets

- | | |
|---|-------------------|
| 1 | Box wheel bracket |
| 2 | Fastening bolt |
| 3 | Washer |
| 4 | Nut |
| 5 | Wheel |

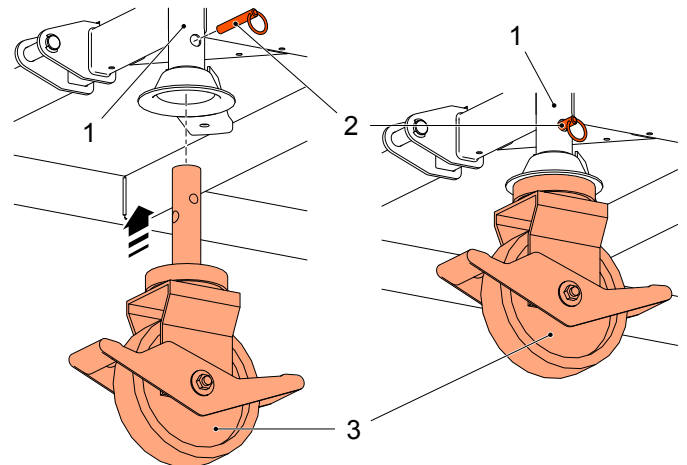

AL-STS063

Figure 37 : Wheels installed on the box feet

Wheels installed on the box feet

- | | |
|---|------------|
| 1 | Box foot |
| 2 | Cotter pin |
| 3 | Wheel |

5.6.3 Assembly of the auxiliary box

EN-AL-10-17-0008-01

Assemble the auxiliary box¹⁾ to transport the smallest parts of the scaffolding.

1. Position the auxiliary box on one of the short profiles of the upper frame of the box.
2. Secure the auxiliary box with the chains.

NOTICE



1) The auxiliary box is not supplied with the scaffolding transport system.
Optionally, Alimak can supply the auxiliary box.

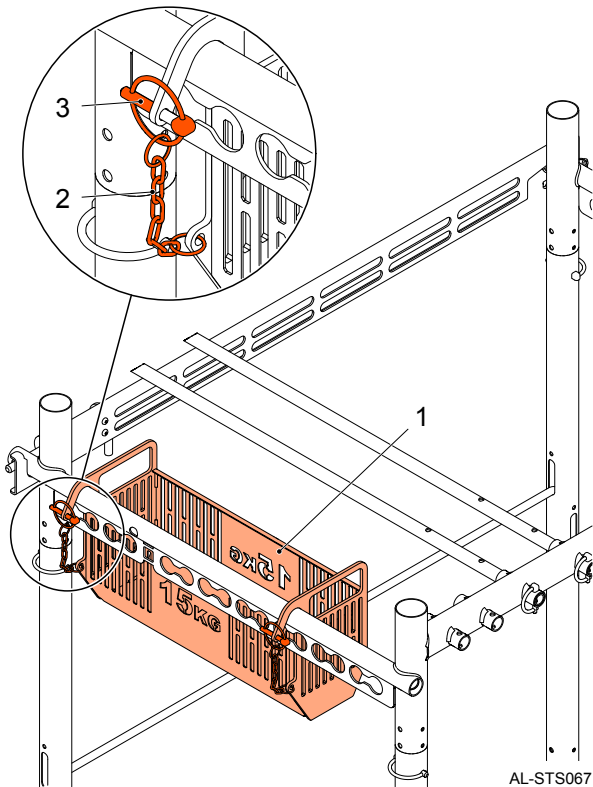

Figure 38 : Auxiliary box

Auxiliary box

- | | |
|---|---------------|
| 1 | Auxiliary box |
| 2 | Chain |
| 3 | Cotter pin |

5.6.4 Adjusting the height of the anchoring system

EN-AL-10-17-0002-01

Adjust the height of the anchoring system before coupling the box:

1. Loosen the nut and disassemble the anchoring system fixing plate.
2. Loosen and remove the two bolts for adjusting the height of the anchoring system.
3. Position the anchoring system. The anchoring system connection points must be at a lower height than the box anchor points.
4. Mount and tighten the two bolts for adjusting the height of the anchoring system.
5. Mount the anchoring system fixing plate and tighten the nut.

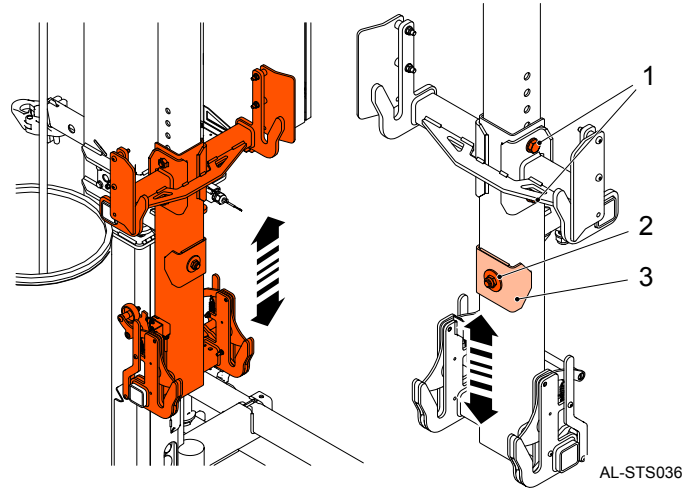

Figure 39 : Adjusting the height of the anchoring system

Adjusting the height of the anchoring system

- | | |
|---|-------------------------------|
| 1 | Height adjustment bolts |
| 2 | Nut |
| 3 | Anchoring system fixing plate |

5.6.5 Coupling the box to the anchoring system

EN-AL-10-17-0003-01

WARNING



Risk of damage to the anchoring system.

Correctly position the box anchor points with the anchoring system connection points to avoid hitting and damaging it.

1. Move the box to the anchoring system and position the four box anchor points above the anchoring system connection points.
2. Turn the Mode of use selector on the main control box to the Box coupling mode position [Refer to section [Main control box](#), see on page 16].
3. Press and hold the UP button on the main control box until the four box anchor points are inserted simultaneously into the box anchoring system connection points and the bottom limit switch exceeds the bottom limit cam and stops.
4. Check that the box is correctly anchored and the box fastening system is closed.
5. Turn the Mode of use selector on the main control box to the Transport mode position.

- Press and hold the DOWN button on the main control box until the box wheels come into contact with the ground and the four box anchor points are released from the anchoring system connection points. Check that the box fastening system opens during the descent¹⁾.

NOTICE



¹⁾Stop the scaffolding transport system immediately if the anchoring system does not open during the box descent.

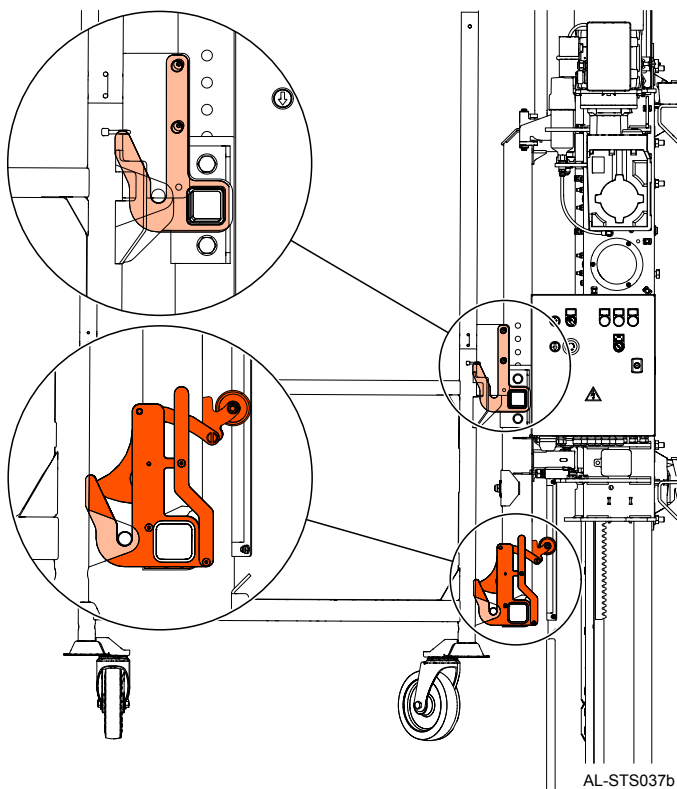
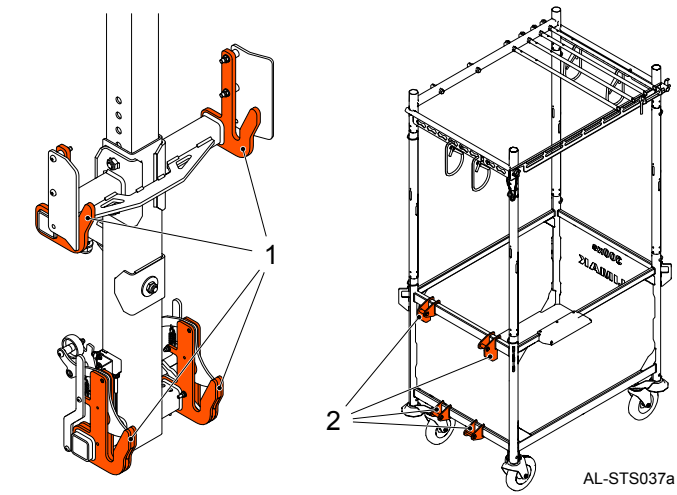

Figure 40 : Connecting the box to the anchoring system

Connecting the box to the anchoring system

- Box anchoring system
- Box anchor points

5.6.6 Uncoupling the box from the anchoring system

EN-AL-10-17-0004-01

- Descend the scaffolding transport system until the bottom limit switch comes into contact with the bottom limit cam and stops.
- Turn the Mode of use selector on the main control box to the Box coupling mode position [Refer to section [Main control box](#), see on page 16].

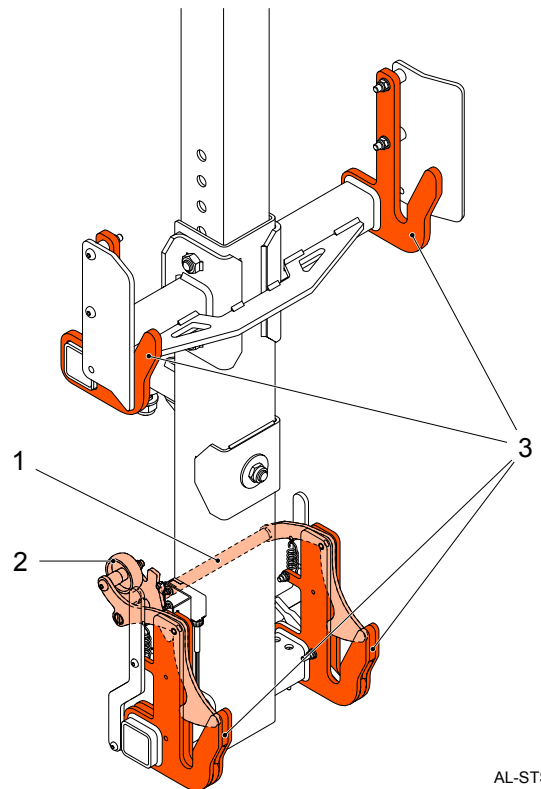

Figure 41 : Uncoupling the box from the anchoring system

Uncoupling the box from the anchoring system

- Box fastening system
- Box fastening system release wheel
- Box anchor points

5.7 Adjusting the top limit sensor

EN-AL-10-17-0005-01

It is possible to adjust the position of the upper stop by adjusting the height of the top limit sensor on its bracket.

1. Loosen the fastening bolt of the top limit sensor.
2. Adjust the top limit sensor position to the required height.
3. Tighten the fastening bolt of the top limit sensor.

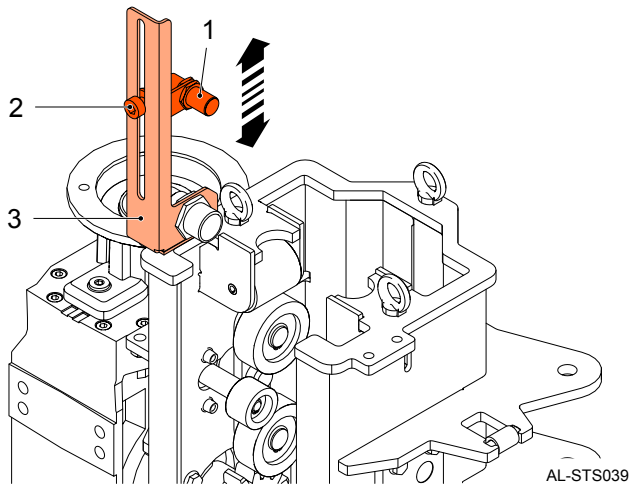

Figure 42 : Adjusting the top limit sensor

Adjusting the top limit sensor

- | | |
|---|--------------------------|
| 1 | Top limit sensor |
| 2 | Fastening bolt |
| 3 | Top limit sensor bracket |

5.8 Inspection prior to use

EN-AL-10-07-0002-01

NOTICE



Record the result of the inspection prior to use in the Appendix: User Log.

5.8.1 General

EN-AL-10-07-0003-01

Function / System	Operations
Base unit	<p>Visually check that there are no cracks, dents and disparities on the following parts of the scaffolding transport system and components:</p> <ul style="list-style-type: none"> • Drive system • Guiding system • Overspeed safety device • Base frame control box • Main control box • Switches and sensors • Electrical cables, elements for securing cables and electrical connections • 2 m cam. • Box anchoring system • Base frame <ul style="list-style-type: none"> – Shock absorbers – Cable collect bin – Bottom limit cam – Emergency bottom limit cam – Box fastening system release cam – First mast section and rack – Adjustable base plates on the base frame fixed correctly
Installation components	<ul style="list-style-type: none"> • Visually check the scaffolding anchoring systems.
Travel path	<ul style="list-style-type: none"> • Visually check that there are no obstacles in the travel path of the scaffolding transport system.
Hour counter	<ol style="list-style-type: none"> 1. Open the main control box door. 2. Check the reading of the hour counter. Record the hour counter reading on the User log. 3. Close the main control box door.

5.8.2 Control and safety devices

5.8.2.1 Scaffolding transport system control

EN-AL-10-07-0001-01

Function / System	Operations
Main switch	<ol style="list-style-type: none"> 1. Turn the main switch on the base frame control box to the OFF position [Refer to section Base frame control box, see on page 17]. 2. Turn the Mode of use selector on the main control box to the Box coupling mode position [Refer to section Main control box, see on page 16]. 3. Press and hold the UP button on the main control box, release it and then press and hold the DOWN button (It is not necessary to couple the box to carry out the check). The scaffolding transport system should not ascend or descend. 4. Turn the main switch on the base frame control box to the ON position.
Emergency stop button (Main control box / User control station)	<ol style="list-style-type: none"> 1. Couple the box to the drive unit [Refer to section Installation of the box, see on page 31]. 2. Press and hold the UP button on the user control station to ascend the scaffolding transport system approximately 1 m. 3. Push the emergency stop button on the user control station [Refer to section User control station, see on page 17]. 4. Press and hold the UP button on the user control station, release it and then press and hold the DOWN button. The scaffolding transport system should not ascend or descend. 5. Deactivate the emergency-stop button. 6. Descend the scaffolding transport system until the bottom limit switch comes into contact with the bottom limit cam [Refer to section Bottom limit switch, see on page 18]. The scaffolding transport system should stop. 7. Turn the Mode of use selector on the main control box to the Box coupling mode position [Refer to section Main control box, see on page 16]. 8. Push the emergency-stop button on the main control box. 9. Press and hold the UP button on the main control box, release it and then press and hold the DOWN button The scaffolding transport system should not ascend or descend.
Bottom limit switch	<ol style="list-style-type: none"> 1. Press and hold the UP button on the main control box until the bottom limit switch exceeds the bottom limit cam and stops [Refer to section Bottom limit switch, see on page 18]. The scaffolding transport system should stop. 2. Turn the Usage mode selector on the main control box to the Transport mode position [Refer to section Main control box, see on page 16]. 3. Press and hold the DOWN button on the user control station until the bottom limit switch comes into contact with the bottom limit cam and stops. The scaffolding transport system should stop.
Top limit sensor	<ol style="list-style-type: none"> 1. Turn the Mode of use selector on the main control box to the Box coupling mode position [Refer to section Main control box, see on page 16]. 2. Press and hold the UP button on the main control box until the bottom limit switch exceeds the bottom limit cam and stops [Refer to section Bottom limit switch, see on page 18]. The scaffolding transport system should stop. 3. Turn the Mode of use selector on the main control box to the Transport mode position. 4. Press and hold the UP button on the user control station until the top limit sensor stops detecting the mast after exceeding the upper end of the last section installed [Refer to section Top limit sensor, see on page 18]. The scaffolding transport system should stop when the top limit sensor exceeds the upper end of the last mast section installed. The emergency top limit sensor should remain activated.

5.9 Prohibited uses

EN-AL-07-02-0001-01

DANGER



Risk of injuries. Failing to observe the warnings may have extremely dangerous consequences for the physical well-being of the users.

The following actions are prohibited:

- Using the scaffolding transport system for purposes other than those intended.
- Transporting persons, tools and objects other than the scaffolding assembly parts.
- Using the scaffolding transport system without following the safety warnings and operating instructions.
- Overloading the scaffolding transport system.
- Manipulating switches, sensors or safety devices.
- Attempting to repair the scaffolding transport system components. Only certified technicians are authorised to perform maintenance work on the scaffolding transport system.
- Placing scaffolding assembly parts outside of the space intended for transporting these parts in the box.

5.10 Using the scaffolding transport system

EN-AL-07-03-0001-01

DANGER



Risk of injuries. Check that nobody is exposed to danger below the scaffolding transport system, for instance, due to falling parts.

DANGER



Risk of injuries. Check that nobody is on the intermediate levels of the scaffolding while the scaffolding transport system is in use.

DANGER



Risk of injuries. Prevent equipment/clothes from becoming entangled with the surrounding elements.

Stay clear of the scaffolding transport system travel path area to prevent equipment/clothes from becoming entangled with the scaffolding transport system when it is moving.

DANGER



Risk of injuries. Personnel must comply with the instructions of the scaffolding transport system operator.

Start the scaffolding transport system by turning the main switch on the base frame control box to the ON position [Refer to section [Base frame control box](#), see on page 17].

- Transporting materials to higher levels of the scaffolding:

1. Load the scaffolding materials into the box [Refer to section [Loading materials into the box](#), see on page 39].
2. Couple the box to the drive unit [Refer to section [Installation of the box](#), see on page 31].
3. Turn the Usage mode selector on the main control box to the Transport mode position [Refer to section [Main control box](#), see on page 16].
4. Press and hold the UP button on the user control station to ascend the scaffolding transport system [Refer to section [User control station](#), see on page 17].

5. Release the UP button on the user control station once the safety height of 2 m is exceeded.

The scaffolding transport system will stop once the top level is reached.

6. Turn the turning system lever downwards and turn the box towards the scaffolding.
7. Unload the scaffolding materials from the box [Refer to section [Unloading the materials from the scaffolding](#), see on page 40].
8. Turn the box to the travel position and turn the turning system lever upwards.
9. Press the DOWN button on the user control station to descend the scaffolding transport system.

The scaffolding transport system will stop once the safety height of 2 m is reached.

10. Press and hold the DOWN button on the user control station to descend the scaffolding transport system.
11. Release the DOWN button on the user control station once the bottom level is reached and the scaffolding transport system stops.
12. Turn the Mode of use selector on the main control box to the Box coupling mode position.
13. Uncouple the box from the drive unit [Refer to section [Installation of the box](#), see on page 31].

- Installation of the scaffolding transport system if the scaffolding is already installed:

1. Load the mast sections, the anchoring systems and the cable guides into the box [Refer to section [Loading materials into the box](#), see on page 39].
2. Couple the box to the drive unit [Refer to section [Installation of the box](#), see on page 31].
3. Turn the Usage mode selector on the main control box to the Transport mode position [Refer to section [Main control box](#), see on page 16].
4. Press and hold the UP button on the user control station to ascend the scaffolding transport system [Refer to section [User control station](#), see on page 17].
5. Release the UP button on the user control station once the safety height of 2 m is exceeded.

The scaffolding transport system will stop once the top level is reached.

6. Turn the turning system lever downwards and turn the box towards the scaffolding.
7. Unload two mast sections and the anchoring system from the box [Refer to section [Unloading the materials from the scaffolding](#), see on page 40].
8. Turn the box to the travel position and turn the turning system lever upwards.
9. Press the UP button on the user control station to ascend the scaffolding transport system to the top level.
10. Repeat the process described above from stage 6 to stage 9, until there are no more mast sections in the box or the installation is complete.

5.11 Loading materials into the box and unloading them from it

EN-AL-07-05-0001-01

NOTICE



Load the scaffolding materials into the box in the established order to optimise the scaffolding assembly process and to ensure load distribution.

5.11.1 Loading materials into the box

EN-AL-07-06-0001-01

- Loading complete scaffolding sections:

Load the box with the necessary materials for mounting a specific number of complete scaffolding sections.

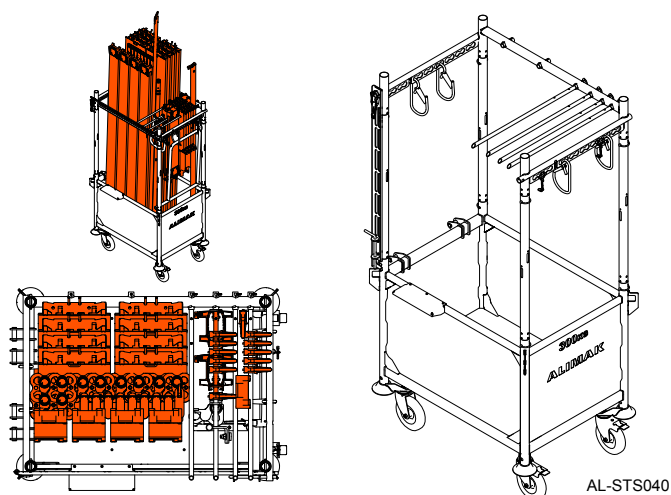

Figure 43 : Loading complete scaffolding sections

- Loading scaffolding parts:

Load the box with the materials required for mounting certain parts of the scaffolding (for e.g. floors and toe boards or guard rails and posts, etc.).

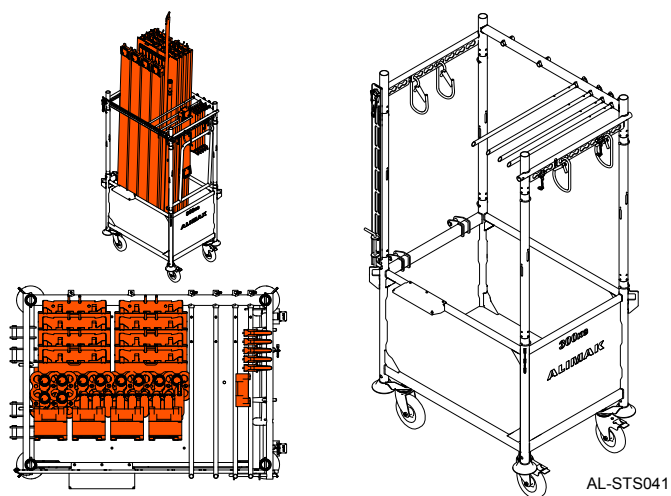

Figure 44 : Loading scaffolding parts

- Loading mast sections in the scaffolding assembly and disassembly processes:

NOTICE



Only load two mast sections per scaffolding level.

- Loading scaffolding parts that are less than 2 m in length:

Mount the rods in the vertical profiles before loading the box with scaffolding parts that are less than 2 m in length.

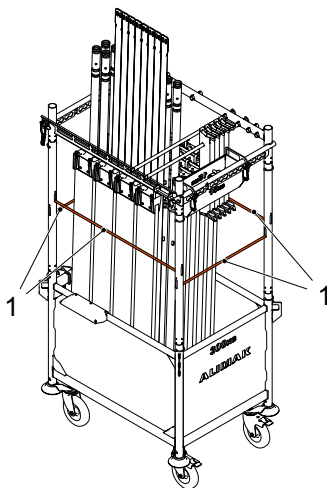

AL-STS068

Figure 45 : Loading scaffolding parts that are less than 2 m in length

Loading scaffolding parts that are less than 2 m in length

1 | Rods

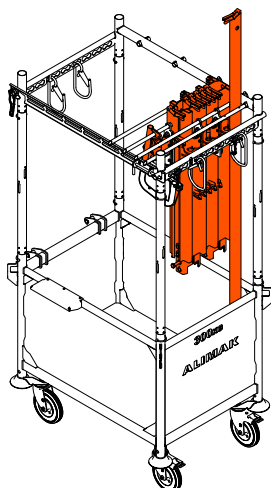

AL-STS042

Figure 46 : Loading mast sections in the scaffolding assembly and disassembly processes

- Loading mast sections in the installation and removal processes of the scaffolding transport system if the scaffolding is already installed:

NOTICE



Load a maximum of six mast sections into the box.

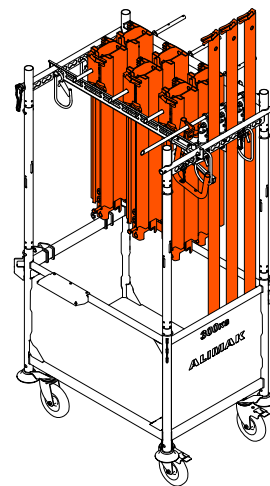

AL-STS043

Figure 47 : Loading mast sections in the installation and removal processes of the scaffolding transport system if the scaffolding is already installed

5.11.2 Unloading the materials from the scaffolding

EN-AL-07-03-0002-01

DANGER



Risk of injuries. Check that the scaffolding safety devices are installed.

DANGER



Risk of injuries. Do not climb onto the toe board or the guard rails of the scaffolding.

DANGER



Risk of injuries. Do not enter the box.

1. Turn the turning system lever downwards and turn the box towards the scaffolding [Refer to section [Turning system](#), see on page 14 and figure [Turning the box](#), see on page 40].
2. Open the safety latch and turn the front profile of the upper frame of the box [Refer to figure [Upper frame of the box](#), see on page 41].
3. Unload the materials from the box [Refer to figure [Upper frame of the box](#), see on page 41 and section [Example of how to unload materials](#), see on page 42].
4. Turn the front profile to place it in its initial position and insert the cotter pin.
5. Turn the box to the travel position and turn the turning system lever upwards.

NOTICE



Use the material support plate to facilitate the process of unloading materials from the scaffolding and maintain a more ergonomic user position.

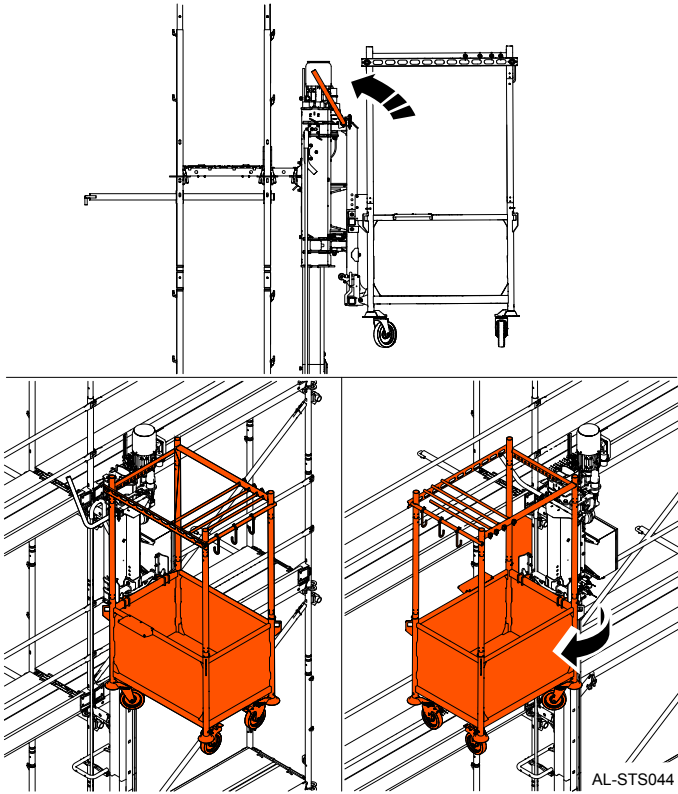

Figure 48 : Turning the box

Turning the box

- 1 | Turning system lever

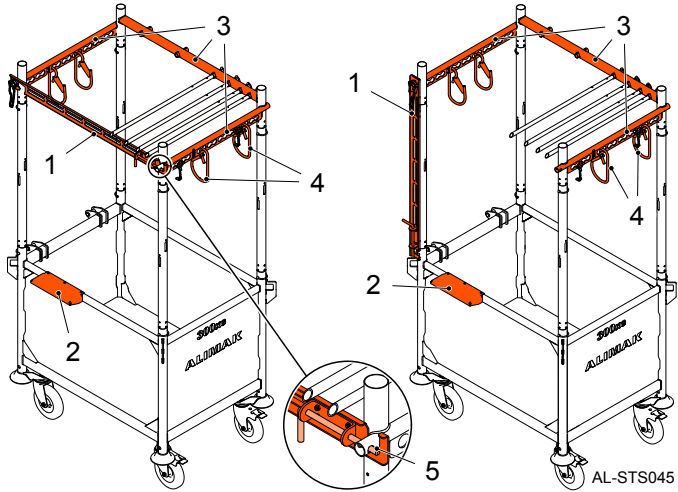

Figure 49 : Upper frame of the box

Upper frame of the box

- 1 | Front profile
- 2 | Material support plate
- 3 | Upper frame of the box
- 4 | Hooks
- 5 | Safety latch

5.11.3 Example of how to unload materials

EN-AL-07-08-0001-01

1. Put the materials next to the scaffolding without lifting them or unloading them from the box [Refer to figure A1, see on page 42].
2. Once the materials are next to the scaffolding guard rail, lift them until they are resting on the material support plate in the box [Refer to figure A2, see on page 42].
3. Once the materials are resting on the support plate, grip them in a lower position [Refer to figure A3, see on page 42].
4. Lift the materials and pass them over the guard rail to put them on the scaffolding [Refer to figure A4, see on page 42].

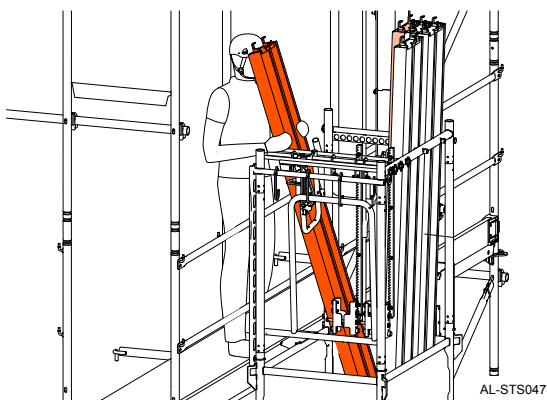

Figure 50 : A1

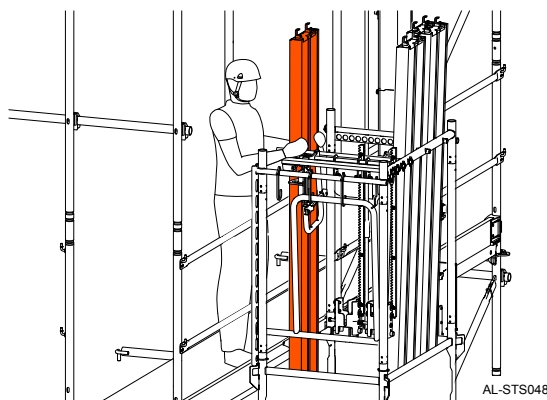

Figure 51 : A2

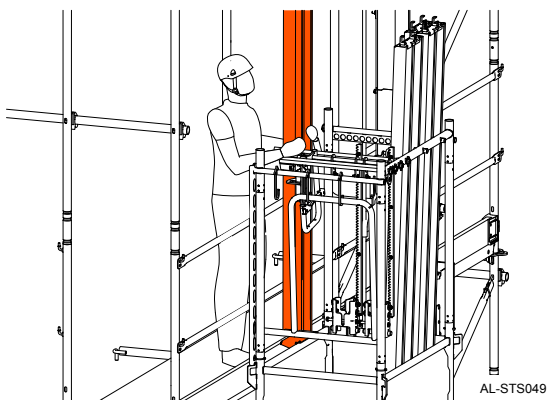

Figure 52 : A3

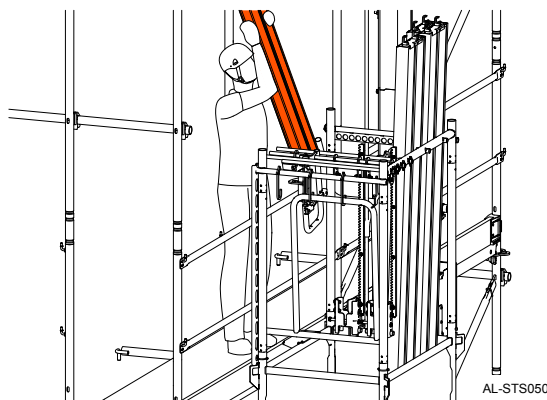

Figure 53 : A4

5.11.4 Installation of the mast prior to installation of the upper level of the scaffolding.

EN-AL-07-09-0001-01

WARNING



Always install the mast sections when completing the assembly of each level of the scaffolding. Otherwise, the material transport system will stop at a level higher than the one where the scaffolding is being mounted.

Install the two upper sections of the mast once the installation of one level of scaffolding is complete [Refer to section *Installation of the mast*, see on page 28].

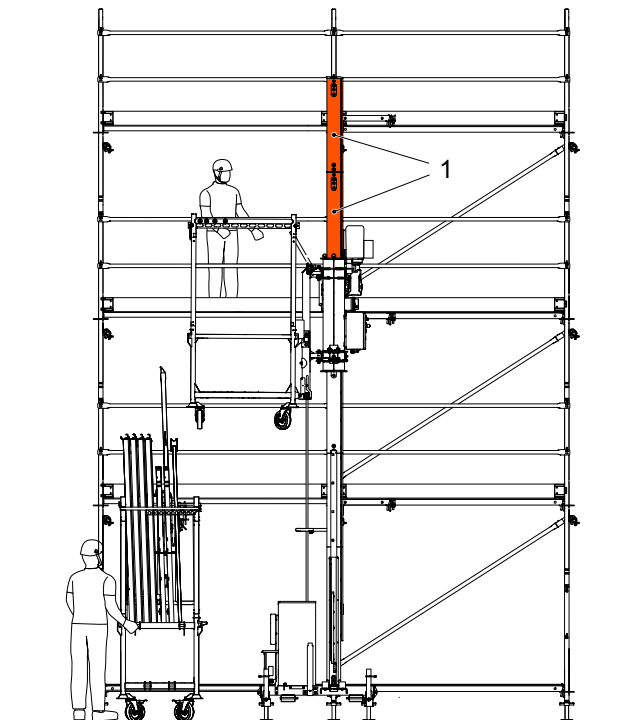

AL-STS051

Figure 54 : Installation of the mast prior to installation of the upper level of the scaffolding.

Installation of the mast prior to installation of the upper level of the scaffolding.

- 1 | Upper sections of the mast

5.12 Disassembly

EN-AL-10-09-0002-01

Disassemble the scaffolding transport system in the reverse order of assembly.

- If necessary, stop the descent of the scaffolding transport system at a level immediately below during the disassembly process:
 1. Press and hold the DOWN button on the user control station to descend the scaffolding transport system to the level immediately below on the scaffolding [Refer to section [User control station](#), see on page 17].
 2. Release the DOWN button on the user control station once the level immediately below is reached and the scaffolding transport system stops.
 3. Turn the turning system lever downwards and turn the box towards the scaffolding.
 4. Load the removed mast sections and components into the box.
 5. Turn the box to the travel position and turn the turning system lever upwards.
- If continuing the descent of the scaffolding transport system to a level immediately below, repeat the process described above from stage 1.
- If it is necessary for the scaffolding transport system to descend to the bottom level on its base:
 1. Press the DOWN button on the user control station to descend the scaffolding transport system.
The scaffolding transport system will stop once the safety height of 2 m is reached.
 2. Press and hold the DOWN button on the user control station until the bottom limit switch comes into contact with the bottom limit cam.
 3. Turn the Mode of use selector on the main control box to the Box coupling mode position [Refer to section [Main control box](#), see on page 16].
 4. Press and hold the DOWN button on the main control box until the box wheels come into contact with the ground and the four box anchor points are released from the anchoring system connection points. Check that the box fastening system opens during the descent¹⁾.
 5. Uncouple the box from the drive unit [Refer to section [Installation of the box](#), see on page 31].

NOTICE



¹⁾Stop the scaffolding transport system immediately if the fastening system does not open during the box descent.

5.13 Troubleshooting

EN-AL-07-15-0001-01

DANGER



Risk of injuries. In case of damage or malfunction, stop the scaffolding transport system immediately. Observe the instructions, procedures, conditions of use, and warnings in this manual at all times.

DANGER



Risk of falling. A damaged or defective drive system or overspeed safety device seriously compromises the safety of the scaffolding transport system. In case of damage or malfunction, replace or repair the drive system or overspeed safety device immediately.

DANGER



Electrical hazard. Switch off the electrical power supply before opening any control boxes on the scaffolding transport system.

Only certified technicians are authorised to perform inspections and repairs on the electrical components. The electrical diagram may be found in the document holder containing the documentation for the scaffolding transport system.

Only certified technicians are authorised to perform repairs or adjustments on the drive system, overspeed safety device and scaffolding transport system components.

Cause	Solution
THE SCAFFOLDING TRANSPORT SYSTEM DOES NOT ASCEND OR DESCEND	

A1 Obstruction

Scaffolding transport system obstructed by an obstacle in the travel path.

1. Carefully remove the obstacle.
2. Check the functional safety of the affected scaffolding sections.
3. Inform the supervisor.

A2 Safety switches/sensors

Emergency top limit sensor deactivated.

1. Perform a manual descent to an accessible level.
2. Check whether or not it is necessary to adjust or repair the emergency top limit sensor.
3. Check whether or not it is necessary to adjust or repair the top limit sensor.

Emergency bottom limit switch activated.

1. Position the selector on the main control box in the I position.
2. Raise the system until the emergency bottom limit switch is released from the activation cam.
3. Check whether or not it is necessary to adjust or repair the emergency bottom limit switch or cam.
4. Check whether or not it is necessary to adjust or repair the bottom limit switch or cam.

Cause	Solution
THE SCAFFOLDING TRANSPORT SYSTEM DOES NOT ASCEND OR DESCEND	
A3 Box detection switch	
Box detection switch activated.	<ol style="list-style-type: none"> 1. Check that the box is correctly positioned in the anchoring system. 2. Check whether or not it is necessary to adjust or repair the box detection switch. 3. Check whether or not it is necessary to adjust or repair the box detection switch activation cam.
A4 Box fastening system switch	
Box anchoring system switch activated with the fastening system outside of the box anchor area.	<ol style="list-style-type: none"> 1. Check that the Mode of use selector on the main control box is in the Transport mode position. 2. Check whether or not it is necessary to adjust or repair the box fastening system switch activation mechanism. 3. Check whether or not it is necessary to adjust or repair the box fastening system switch.
Box anchoring system switch deactivated with the fastening system inside the box anchor area.	<ol style="list-style-type: none"> 1. Check that the Mode of use selector on the main control box is in the Box coupling mode position. 2. Check that the box does not interfere with the movement of the box fastening system switch activation mechanism. 3. Check whether or not it is necessary to adjust or repair the box fastening system switch activation mechanism. 4. Check whether or not it is necessary to adjust or repair the box fastening system switch.
A5 Turning system not locked in the travel position	
Rotation switch activated.	<ol style="list-style-type: none"> 1. Check that the turning system is in the travel position and mechanically locked. 2. Perform a manual descent to an accessible level. 3. Check whether or not it is necessary to adjust or repair the rotation switch or the drive bush.
A6 Overspeed safety device	
Overspeed safety device activated as a result of the drive system failing	<ol style="list-style-type: none"> 1. Stop the scaffolding transport system immediately. 2. Inform the supervisor
Overspeed safety device activated as a result of the rack failing	<ol style="list-style-type: none"> 1. Stop the scaffolding transport system immediately. 2. Inform the supervisor
A7 Emergency stop on the user control station	
Emergency stop button activated on the user control station.	Deactivate the emergency-stop button.
A8 Emergency stop on the main control box	
Emergency stop button activated on the main control box.	Deactivate the emergency-stop button.
A9 Main switch	
Main switch is in the OFF position.	Turn the main switch ON.

Cause	Solution
THE SCAFFOLDING TRANSPORT SYSTEM DOES NOT ASCEND OR DESCEND	
A10 Control or power failure	
Electrical power supply interrupted or control failure.	<ol style="list-style-type: none"> 1. Perform a manual descent to an accessible level. 2. Identify the cause of the failure or wait until the electrical power supply is restored. 3. Check for possible failures in the scaffolding transport system's control circuit.
A11 Electromagnetic brake	
Electromagnetic brake engaged.	Repair any power faults or replace electromagnetic brake.
Electromagnetic brake defective.	Replace the defective electromagnetic brake.
Rectifier defective.	Replace defective rectifier.
Power fault on electromagnetic brake.	<ol style="list-style-type: none"> 1. Stop the scaffolding transport system immediately. 2. Inform the supervisor
A12 Motor over-temperature protection	
Lack of cooling to motor.	Clean the motor cover.
Voltage out of range.	<ol style="list-style-type: none"> 1. Measure voltage and power consumption on the loaded motor. 2. Correct voltage of electrical power supply.
A13 Motor protection circuit breaker tripped	
Start-up capacitor defective.	<ol style="list-style-type: none"> 1. Inform the supervisor. 2. Replace the defective start-up capacitor.
Start-up capacitor disconnect relay defective.	<ol style="list-style-type: none"> 1. Inform the supervisor. 2. Replace the defective start-up capacitor disconnect relay.
Short circuit in the motor.	<ol style="list-style-type: none"> 1. Inform the supervisor. 2. Eliminate the short circuit in the motor.
A14 Circuit breaker tripped	
Short circuit in the installation	Check whether or not it is necessary to repair damaged connections, wiring, lights or buttons and switches or sensors.
Overload due to a damaged component or defective connection.	Check whether or not it is necessary to repair damaged connections, lights or buttons and switches or sensors.
A15 Overload	
Overload in the box.	Check and/or reduce the load until the overload warning stops.
A16 User control station	
User control station poorly connected	Connect the user control station correctly.
User control station connector dirty or in poor condition	<ol style="list-style-type: none"> 1. Clean the user control station connector removing traces of dirt or rust. 2. Check for missing or loose pins on the user control station connector. 3. Replace the user control station connector if necessary.

<i>Cause</i>	<i>Solution</i>
--------------	-----------------

THE SCAFFOLDING TRANSPORT SYSTEM DOES NOT ASCEND OR DESCEND

A17 Power cable

Power cable severed or damaged.

1. Visually check whether the power cable is damaged or severed and replace if necessary.
2. Replace the power cable if necessary.
3. Check the connection of the electrical power supply connector to the base frame control box.

THE SCAFFOLDING TRANSPORT SYSTEM ASCENDS BUT DOES NOT DESCEND

B1 Obstruction

Obstacle in the travel path below the scaffolding transport system.

1. Ascend the scaffolding transport system a few centimetres and carefully remove the obstacle.
2. Check the functional safety of the affected scaffolding sections.
3. Inform the supervisor.

B2 Bottom limit switch

Bottom limit switch activated

1. Check that the Mode of use selector on the main control box is in the Transport mode position.
2. Check whether or not it is necessary to adjust or repair the bottom limit switch.

B3 DOWN control circuit

Malfunction in the scaffolding transport system's DOWN control circuit.

Check and, if necessary, repair connections, wiring and relays.

B4 Main control box selector

SERVICE selector on the main control box in the "I" position.

1. Perform a manual descent to an accessible level.
2. Position the selector in the "O" position.

B5 Box fastening system switch / box detection switch

Box fastening system switch deactivated and box detection switch activated.

1. Check that the Mode of use selector on the main control box is in the Box coupling mode position.
2. Check whether or not it is necessary to adjust or repair the box fastening system switch and/or the box detection switch.

THE SCAFFOLDING TRANSPORT SYSTEM DESCENDS BUT DOES NOT ASCEND

C1 Obstruction

Obstacle in the travel path above the scaffolding transport system.

1. Descend the scaffolding transport system a few centimetres and carefully remove the obstacle.
2. Check the functional safety of the affected scaffolding sections.
3. Inform the supervisor.

C2 Top limit sensor

Top limit sensor deactivated.

1. Descend the scaffolding transport system to the lower level.
2. Check whether or not it is necessary to adjust or repair the top limit sensor.

<i>Cause</i>	<i>Solution</i>
THE SCAFFOLDING TRANSPORT SYSTEM DESCENDS BUT DOES NOT ASCEND	
C3 UP control circuit	
Malfunction in the scaffolding transport system's UP control circuit.	Check and, if necessary, repair connections, wiring and relays.
A LIGHT IS NOT LIT ALTHOUGH OPERATION IS NORMAL	
D Lights	
Light burnt out or defective.	Replace light.
HIGH NOISE LEVEL AND/OR SMOKE FROM THE DRIVE SYSTEM MOTOR	
F1 Electromagnetic brake	
Electromagnetic brake is completely or partially engaged while moving.	<ol style="list-style-type: none"> 1. Stop the scaffolding transport system immediately. 2. Inform the supervisor.
F2 Motor start-up capacitor	
Motor start-up capacitor defective.	<ol style="list-style-type: none"> 1. Stop the scaffolding transport system immediately. 2. Perform a manual descent to an accessible level. 3. Replace the start-up capacitor.
Start-up capacitor disconnect relay not working correctly.	<ol style="list-style-type: none"> 1. Stop the scaffolding transport system immediately. 2. Inform the supervisor.
THE SCAFFOLDING TRANSPORT SYSTEM STRUGGLES TO START OR DOES NOT START	
G1 Overload system	
The overload system is not properly adjusted.	<ol style="list-style-type: none"> 1. Descend the scaffolding transport system to the lower level. 2. Adjust the overload system.
G2 Motor start-up capacitor	
Motor start-up capacitor defective.	<ol style="list-style-type: none"> 1. Stop the scaffolding transport system immediately. 2. Perform a manual descent to an accessible level. 3. Replace the start-up capacitor.
G3 Electrical power supply	
Motor input voltage too low.	<ol style="list-style-type: none"> 1. Measure the voltage and power consumption on the motor. 2. Correct voltage of electrical power supply.
G4 Guiding system	
Guiding system maladjusted, damaged or defective.	<ol style="list-style-type: none"> 1. Check that the guiding system adjustment is correct and there is no friction. 2. Check and replace the guiding system elements if they are worn, broken or defective.

Cause	Solution
HIGH NOISE LEVEL OF THE DRIVE SYSTEM, BUT THE SCAFFOLDING TRANSPORT SYSTEM CAN ASCEND AND DESCEND	
H1 Rack	
Rack insufficiently lubricated.	Lubricate the rack.
The rack is dirty or has metal shavings.	<ol style="list-style-type: none"> 1. Descend the scaffolding transport system to the lower level. 2. Clean and lubricate the rack.
Rack worn.	<ol style="list-style-type: none"> 1. Descend the scaffolding transport system to the lower level. 2. Replace the worn rack sections.
H2 Drive pinion	
Drive pinion worn.	Replace the worn drive pinion.
H3 Guiding system	
Guiding system maladjusted.	Adjust the guiding system.
H4 Drive system	
Drive system defective.	<ol style="list-style-type: none"> 1. Stop the scaffolding transport system immediately. 2. Inform the supervisor.
THE SCAFFOLDING TRANSPORT SYSTEM CONTINUES TO DESCEND UNEXPECTEDLY	
I1 Electromagnetic brake	
Electromagnetic brake misadjusted.	Adjust the electromagnetic brake.
Electromagnetic brake worn.	Replace the worn electromagnetic brake.
Electromagnetic brake defective.	Replace the defective electromagnetic brake.
I2 Drive system	
Drive system defective.	<ol style="list-style-type: none"> 1. Stop the scaffolding transport system immediately. 2. Inform the supervisor.
THE COUPLING AND/OR UNCOUPLING OF THE BOX TO THE ANCHORING SYSTEM IS NOT CORRECT	
J1 Anchoring system	
The height of the anchoring system is not correct.	<ol style="list-style-type: none"> 1. Check that the four box anchor points are above the anchoring system connection points. 2. Check whether or not it is necessary to adjust the height of the anchoring system.
Fastening system mechanism misadjusted or damaged.	<ol style="list-style-type: none"> 1. Check that the anchoring system mechanism is adjusted and the release cam of the box fastening system activates the box fastening system switch. 2. Check and replace the fastening system mechanism elements if they are worn, broken or defective.
J2 Base frame levelling	
Uneven base frame.	<ol style="list-style-type: none"> 1. Check that the base frame is level. 2. Check whether or not it is necessary to adjust the height of the adjustable base plates to level the base frame.
J3 Usage mode selector on the main control box	
Usage mode selector in the wrong position.	<ol style="list-style-type: none"> 1. Turn the Mode of use selector on the main control box to the Box coupling mode position.

<i>Cause</i>	<i>Solution</i>
THE SCAFFOLDING TRANSPORT SYSTEM IS TILTED (MISALIGNED) EXCESSIVELY	
K1 Guiding system	
Guiding system misadjusted, damaged or defective	<ol style="list-style-type: none"> 1. Check and replace the guiding system elements if they are worn, broken or defective. 2. Check that the guiding system structure has no dents, cracks or deformations that could cause misadjustments. 3. Adjust the guiding system.
K2 Box	
Box damaged.	<ol style="list-style-type: none"> 1. Check that the box structure and mounting pins have no dents, cracks or deformations that could cause misadjustments.
K3 Mast	
Incorrect installation of the mast	<ol style="list-style-type: none"> 1. Check there are no connections that are poorly tightened. 2. Check that the anchors are installed correctly. 3. Check that the fixing plates for the anchoring system brackets are installed correctly on the mast.
THE SCAFFOLDING TRANSPORT SYSTEM DOES NOT STOP AT THE SAFETY HEIGHT OF 2 M OR STOPS AT A LOWER HEIGHT	
L1 2 m zone switch activation cam	
2 m zone switch activation cam in the transport position.	<ol style="list-style-type: none"> 1. Slide the 2 m zone switch activation cam upwards and fix it in place.
L2 2 m zone switch	
2 m zone switch misadjusted.	Check whether or not it is necessary to adjust or repair the 2 m zone switch.
THE SCAFFOLDING TRANSPORT SYSTEM DOES NOT STOP AT A LOWER OR UPPER LEVEL WHEN PRESSING AND HOLDING THE UP OR DOWN BUTTON ON THE USER CONTROL STATION	
M1 Level sensor	
Level sensor misadjusted.	Check whether or not it is necessary to adjust or repair the level sensor.
M2 Level detection cam	
Level detection cam damaged.	<ol style="list-style-type: none"> 1. Visually check whether the level detection cam is damaged and replace if necessary.

6 Maintenance

EN-AL-11-00-0004-01

This manual does not exhaustively describe operations, general-purpose tools, general safety protocols or specify the sequence of inspection and maintenance of the scaffolding transport system.

Only certified technicians are authorised to perform scaffolding transport system annual maintenance following the installation and maintenance checklist.

The maintenance instructions for the scaffolding transport system form part of the familiarisation procedure.

Depending on the conditions of use and operation of the scaffolding transport system or in accordance with local regulations, inspections may be required more frequently than that established in the maintenance planning.

NOTICE



Write the result of maintenance inspections and repairs performed on the scaffolding transport system in the Appendix: Installation and maintenance log.

6.1 Maintenance planning

EN-AL-11-04-0000-01

Frequency	Performed by	Function / System
Each new installation	User	General
		Control and safety devices
Weekly	User	General
		Control and safety devices
Every 6 months or more often according to local regulations	User	Overspeed safety device test
Every year or 150 hours of operation (whichever comes first)	Certified technician	General
		Control and safety devices
		Emergency limit switch and sensor
		Drive system
		Rack and pinion
		Lubrication system
		Turning system
		Guiding system
		Cable management system
		Mast
		Control boxes
Checking the overload system		
Informative signs and documentation		
Every 4 years	Alimak Manufacturing S.L. (workshop)	Overspeed safety device overhaul
Every 5 years	Certified technician	Replacing the motor start-up capacitor
Every 8 years	Certified technician	Replacing the overspeed safety device
Every 10 years	Certified technician	Replacing the emergency top limit sensor

6.1.1 General

EN-AL-11-00-0005-01

Function / System	Operations
Base unit	<p>Before starting the installation, visually check that all parts of the scaffolding transport system are present and in good condition. Visually check that there are no areas with excessive corrosion, cracks and/or dents, loose connection elements, lack of tightness and damage on the electrical connections or any other disparity that could alter the normal operation of the scaffolding transport system.</p> <ul style="list-style-type: none"> • Drive system • Guiding system • Overspeed safety device • Base frame control box • Main control box • Switches and sensors • Electrical cables, elements for securing cables and electrical connections • 2 m cam. • Box anchoring system • Informative signs and documentation • Base frame <ul style="list-style-type: none"> – Shock absorbers – Cable collect bin – Bottom limit cam – Emergency bottom limit cam – Box fastening system release cam – First mast section and rack – Adjustable base plates on the base frame fixed correctly
Box	<p>Visually check that there are no cracks, dents and disparities on the different parts of each transport box.</p> <ul style="list-style-type: none"> • Box anchor points • Ground • Upper frame of the box • Wheels
Masts	<p>Visually check that there are no cracks, dents, connection elements in poor condition and disparities on the different parts of the mast sections:</p> <ul style="list-style-type: none"> • Rack • Connectors • Aluminium body
Anchor bracket/ cable guide	<p>Visually check whether any components are missing or whether there are any noticeable defects:</p> <ul style="list-style-type: none"> • Scaffolding anchor brackets • Cable guides

Function / System	Operations
Trailing cable	<ol style="list-style-type: none"> Ascend and descend the scaffolding transport system a few metres. Visually check the trailing cable and the uncoiling and coiling of the trailing cable inside the cable collect bin. <p>When ascending, the scaffolding transport system must pull the trailing cable and uncoil it from the inside of the cable collect bin without jerks and without interfering or becoming entangled with other components.</p> <p>When descending the scaffolding transport system, the trailing cable must coil inside the cable collect bin without interfering or becoming entangled with other components.</p> <p>The trailing cable must not have damage to the sheath, indentations, compression marks or marks caused by heat.</p>
Travel path	<ol style="list-style-type: none"> Visually check the travel path of the scaffolding transport system. <p>The scaffolding transport system's travel path must be free of obstacles.</p>
Lubrication system	Check the level of grease [Refer to section Lubrication system , see on page 59 and the appendix Checking the lubrication system , see on page 67].
Hour counter	<ol style="list-style-type: none"> Open the main control box door. Check the reading of the hour counter. <p>Record the hour counter reading on the User log/Installation and maintenance log.</p> <ol style="list-style-type: none"> Close the main control box door.

6.1.2 Control and safety devices

EN-AL-11-04-0014-01

WARNING



The scaffolding transport system must be installed, anchored and have a minimum mast height of 2.5 m (base unit and first mast section) before carrying out any functional test.

Function / System	Operations
Box detection switch	<ol style="list-style-type: none"> Turn the main switch on the base frame control box to the ON position [Refer to section Base frame control box, see on page 17]. Turn the Mode of use selector on the main control box to the Box coupling mode position [Refer to section Main control box, see on page 16]. Uncouple the box from the drive unit [Refer to section Installation of the box, see on page 31]. Press and hold the UP button on the main control box until the box fastening system exceeds the release cam and is closed completely. <p>The scaffolding transport system should stop.</p> <p>The scaffolding transport system ready light (green) should turn off.</p> <ol style="list-style-type: none"> Press and hold the UP button on the main control box, release it and then press and hold the DOWN button <p>The scaffolding transport system should not ascend or descend.</p> <ol style="list-style-type: none"> Turn the Mode of use selector on the main control box to the Transport mode position. Press and hold the UP button on the user control station, release it and then press and hold the DOWN button. <p>The scaffolding transport system should not ascend or descend.</p> <ol style="list-style-type: none"> Pull the electromagnetic motor brake release lever upwards [Refer to section Drive system, see on page 13], until the box fastening system comes into contact with the release cam and is completely open. Turn the Mode of use selector on the main control box to the Box coupling mode position. Press and hold the DOWN button on the main control box. <p>The scaffolding transport system should descend.</p> <ol style="list-style-type: none"> Release the DOWN button on the main control box once the bottom level is reached and the scaffolding transport system stops.

Function / System	Operations
Box fastening system switch	<ol style="list-style-type: none"> 1. Turn the main switch on the base frame control box to the ON position [Refer to section Base frame control box, see on page 17]. 2. Couple the box to the drive unit without load [Refer to section Installation of the box, see on page 31]. 3. Press and hold the UP button on the main control box until the scaffolding transport system stops. 4. Manually open the box fastening system and fix it in that position using the holes for this operation. 5. Turn the Usage mode selector on the main control box to the Transport mode position [Refer to section Main control box, see on page 16]. 6. Press and hold the UP button on the user control station. <p>The scaffolding transport system should not ascend.</p>
Main switch	<ol style="list-style-type: none"> 1. Turn the main switch on the base frame control box to the OFF position [Refer to section Base frame control box, see on page 17]. 2. Turn the Mode of use selector on the main control box to the Box coupling mode position [Main control box, see on page 16]. 3. Press and hold the UP button on the main control box, release it and then press and hold the DOWN button (It is not necessary to couple the box to carry out the check). <p>The scaffolding transport system should not ascend or descend.</p> <ol style="list-style-type: none"> 4. Turn the main switch on the base frame control box to the ON position.
Emergency stop button (Main control box / User control station)	<ol style="list-style-type: none"> 1. Couple the box to the drive unit [Refer to section Installation of the box, see on page 31]. 2. Press and hold the UP button on the user control station to ascend the scaffolding transport system approximately 1 m. 3. Push the emergency stop button on the user control station [Refer to section User control station, see on page 17]. 4. Press and hold the UP button on the user control station, release it and then press and hold the DOWN button. <p>The scaffolding transport system should not ascend or descend.</p> <ol style="list-style-type: none"> 5. Deactivate the emergency-stop button. 6. Push the emergency-stop button on the main control box. 7. Press and hold the UP button on the user control station, release it and then press and hold the DOWN button. <p>The scaffolding transport system should not ascend or descend.</p> <ol style="list-style-type: none"> 8. Deactivate the emergency-stop button. 9. Descend the scaffolding transport system until the bottom limit switch comes into contact with the bottom limit cam [Refer to section Bottom limit switch, see on page 18]. <p>The scaffolding transport system should stop.</p> <ol style="list-style-type: none"> 10. Turn the Mode of use selector on the main control box to the Box coupling mode position [Refer to section Main control box, see on page 16]. 11. Push the emergency-stop button on the main control box. 12. Press and hold the UP button on the main control box, release it and then press and hold the DOWN button <p>The scaffolding transport system should not ascend or descend.</p> <ol style="list-style-type: none"> 13. Deactivate the emergency-stop button. 14. Push the emergency stop button on the user control station [Refer to section User control station, see on page 17]. 15. Press and hold the UP button on the user control station, release it and then press and hold the DOWN button. <p>The scaffolding transport system should not ascend or descend.</p>

Function / System	Operations
2 m zone switch	<ol style="list-style-type: none"> 1. Turn the Mode of use selector on the main control box to the Box coupling mode position [Refer to section Main control box, see on page 16]. 2. Press and hold the UP button on the main control box until the bottom limit switch exceeds the bottom limit cam and stops [Refer to section Bottom limit switch, see on page 18]. The scaffolding transport system should stop. 3. Turn the Usage mode selector on the main control box to the Transport mode position [Refer to section Main control box, see on page 16]. 4. Press and hold the UP button on the user control station to ascend the scaffolding transport system approximately 1 m. 5. Release the UP button. The scaffolding transport system should stop immediately when the button is released. 6. Press and hold the DOWN button on the user control station to descend the scaffolding transport system approximately 0.5 m. The scaffolding transport system should descend. The acoustic buzzer should sound. 7. Release the DOWN button on the user control station. The scaffolding transport system should stop immediately when the button is released.
Bottom limit switch	<ol style="list-style-type: none"> 1. Press and hold the UP button on the main control box until the bottom limit switch exceeds the bottom limit cam and stops. [Refer to section Bottom limit switch, see on page 18]. The scaffolding transport system should stop. 2. Turn the Usage mode selector on the main control box to the Transport mode position [Refer to Main control box, see on page 16]. 3. Press and hold the DOWN button on the user control station until the bottom limit switch comes into contact with the bottom limit cam and stops. The scaffolding transport system should stop.
Top limit sensor	<ol style="list-style-type: none"> 1. Turn the Mode of use selector on the main control box to the Box coupling mode position [Refer to section Main control box, see on page 16]. 2. Press and hold the UP button on the main control box until the bottom limit switch exceeds the bottom limit cam and stops [Refer to section Bottom limit switch, see on page 18]. The scaffolding transport system should stop. 3. Turn the Mode of use selector on the main control box to the Transport mode position. 4. Press and hold the UP button on the user control station until the top limit sensor stops detecting the mast after exceeding the upper end of the last section installed [Refer to section Top limit sensor, see on page 18]. The scaffolding transport system should stop when the top limit sensor exceeds the upper end of the last mast section installed. The emergency top limit sensor should remain activated.
Turning system switch	<ol style="list-style-type: none"> 1. Ascend the scaffolding transport system until it stops. The scaffolding transport system should stop when the top limit sensor exceeds the upper end of the last mast section installed. 2. Turn the box and put it in the unloading position. The scaffolding transport system ready light (green) should turn off. 3. Press and hold the UP button, release it, and then press and hold the DOWN button. The scaffolding transport system should not ascend or descend.
Level sensor	<ol style="list-style-type: none"> 1. Ascend the scaffolding transport system until the level sensor is aligned with the detection cam of the first anchor bracket. The light on the level sensor should turn on.

6.1.3 Overspeed safety device test

EN-AL-11-04-0015-01

Function / System	Operations
Overspeed safety device test	<p>Only certified technicians are authorised to check the overspeed safety device.</p> <ol style="list-style-type: none"> 1. Put a load of 300 kg into the box for the overspeed safety device test. 2. Couple the box to the anchoring system [Refer to section Coupling the box to the anchoring system, see on page 33]. 3. Connect the free fall test control station inside the main control box [Refer to section Free fall test control station, see on page 17 4. Turn the SERVICE selector on the main control box to the "I" position [Refer to section Main control box, see on page 16 5. Press and hold the UP button on the free fall test control station until the scaffolding transport system ascends approximately 1 m. 6. Press and hold the TEST button on the free fall test control station. The scaffolding transport system should descend and the overspeed safety device should activate when the activation speed is reached. The scaffolding transport system should stop and the overspeed safety device should hold the load. 7. Press and hold the UP button on the free fall test control station until the overspeed safety device is deactivated. 8. Visually check that no structural part or component is damaged. 9. Disconnect the free fall test control station from inside the main control box. 10. Turn the SERVICE selector on the main control box to the "O" position.

6.1.4 Emergency limit switch and sensor

EN-AL-07-01-0016-01

Function / System	Operations
Emergency bottom limit switch	<ol style="list-style-type: none"> 1. Pull the electromagnetic motor brake release lever upwards to lower the scaffolding transport system until it touches the shock absorbers on the base frame. [Refer to section Drive system, see on page 13]. The scaffolding transport system should stop when it comes into contact with the shock absorbers on the base frame. 2. Turn the Usage mode selector on the main control box to the Transport mode position [Refer to section Main control box, see on page 16]. 3. Press and hold the UP button on the user control station. The scaffolding transport system should not ascend. 4. Turn the Mode of use selector on the main control box to the Box coupling mode position. 5. Press and hold the UP button on the main control box until the emergency bottom limit switch is deactivated.
Emergency top limit sensor	<ol style="list-style-type: none"> 1. Position and fix the emergency top limit sensor in test mode. 2. Press and hold the UP button until the emergency top limit sensor stops detecting the mast after exceeding the upper end of the last section installed [Refer to section Emergency top limit sensor, see on page 18]. The scaffolding transport system should stop when the emergency top limit sensor exceeds the upper end of the last mast section installed.

6.1.5 Drive system

EN-AL-07-01-0019-01

Function / System	Operations
Motor-gearbox and gearbox-drive unit connections	<ol style="list-style-type: none"> 1. Check that the connections between the motor and the gearbox, and between the gearbox and the drive unit are tight and in good condition. The connections between the motor and the gearbox, and between the gearbox and the drive unit must be tight and in good condition.
Seals	<ol style="list-style-type: none"> 1. Check the condition of the gearbox shaft seals. The gearbox shaft seals must be in good condition and there must be no oil leaks.
Gearbox	<ol style="list-style-type: none"> 1. Check that the pinion and gearbox shaft covers are tight. The pinion and gearbox shaft covers must be tight. 2. Check the play on the gearbox shaft and bearings. The gearbox shaft and bearings must be free of play. 3. Visually check the condition of the gearbox pressure valve. The gearbox pressure valve must not be damaged or dirty.
Motor junction box	<ol style="list-style-type: none"> 1. Visually check the condition of the motor junction box and electrical cables. The motor junction box must not have dents, cracks, corrosion or other damage. The sealing of the motor junction boxes must be in good condition. The electrical cables must not have damage to the sheath.
Electromagnetic brake	<ol style="list-style-type: none"> 1. Remove the fan protection guard. 2. Check the electromagnetic motor brake [Refer to section Checking and adjustment instructions in the appendix Testing and adjusting the electromagnetic motor brake, see on page 64]. 3. Check the condition of the fan. The fan must not be damaged and must turn with the shaft. Clean any dirt from the fan. 4. Check the condition of the fan protection guard and the motor cover. The fan protection guard and the motor cover must be in good condition. 5. Mount the fan protection guard.

NOTICE



The drive unit must be removed to inspect any of the components.

6.1.6 Rack and pinion

EN-AL-11-04-0001-01

Function / System	Operations
Drive pinion	<ol style="list-style-type: none"> 1. Check the wear of the drive pinion [Refer to appendix Measuring the wear of the rack and drive pinion, see on page 66].
Rack	<ol style="list-style-type: none"> 1. Check the wear of the rack [Refer to appendix Measuring the wear of the rack and drive pinion, see on page 66]. 2. Check that the bolts connecting the rack to the mast are tight. The bolts must be tightened to a tightening torque of 30 N m (±25%). 3. Check the condition of the rack alignment pins. The rack alignment pins must be in good condition and installed correctly.

NOTICE



The drive unit must be removed to inspect any of the components.

6.1.7 Lubrication system

EN-AL-11-04-0002-01

Function / System	Operations
Lubrication system	<ol style="list-style-type: none">1. Check the condition of the lubrication system [Refer to appendix Checking the lubrication system, see on page 67]. The lubrication system must be in good condition, it must not be obstructed or have any leaks.

NOTICE



The drive unit must be removed to inspect any of the components.

6.1.8 Turning system

EN-AL-11-04-0004-01

Function / System	Operations
Locking jaws	<ol style="list-style-type: none">1. Check the condition of the turning system lever. The turning system lever must be in good condition. The locking jaws move and return to the initial position when the turning system lever is operated in both directions.2. Check the condition of the drive springs. The drive springs must be in good condition.3. Visually check the condition of the anchor area. The anchor area must not have any deformations or cracks.
Bearings	<ol style="list-style-type: none">1. Check the condition of the turning system bearings. The bearings must be free of play and the turning system must turn effortlessly.
Adjusting the height of the box anchoring system	<ol style="list-style-type: none">1. Loosen and remove the two bolts for adjusting the height of the box anchoring system [Refer to section Adjusting the height of the anchoring system, see on page 33].2. Loosen the nut and disassemble the box anchoring system fixing plate [Refer to section Adjusting the height of the anchoring system, see on page 33].3. Visually check the condition of the holes and the adjustment guide. The holes and the adjustment guide must not have any deformations.4. Visually check the condition of the bolts for adjusting the height and the threads they are screwed into. The bolts for adjusting the height and the threads they are screwed into must not be damaged or worn.5. Mount the fixing plate and the two bolts for adjusting the height of the box anchoring system.

6.1.9 Box fastening system

EN-AL-11-04-0003-01

Function / System	Operations
Box fastening system	<ol style="list-style-type: none"> 1. Visually check the box fastening system. The box fastening system must not have any deformations or cracks. 2. Check the condition of the box fastening system mechanism. The box fastening system mechanism must be in good condition and must not show any signs of wear or play. The box fastening system mechanism moves and returns to the initial position. 3. Check the condition of the box fastening system springs. The box fastening system springs must be in good condition. 4. Check the box fastening system position in contact with the release cam. The fastening system must be completely open. 5. Couple the box to the drive unit <i>Installation of the box, see on page 31</i>]. 6. Press and hold the UP button on the main control box until the scaffolding transport system stops. 7. Manually open the box fastening system and fix it in that position using the holes for this operation. 8. Turn the Usage mode selector on the main control box to the Transport mode position [Refer to section <i>Main control box, see on page 16</i>]. 9. Press and hold the UP button on the user control station. The scaffolding transport system should not ascend.

6.1.10 Guiding system

EN-AL-11-04-0033-01

Function / System	Operations
Guiding system connections	<ol style="list-style-type: none"> 1. Check that the guiding system connections are tight and in good condition. The guiding system connections must be tight and in good condition.
Drive system counter rollers	<ol style="list-style-type: none"> 1. Check the condition of the drive system counter rollers and the side seals. The drive system counter rollers and the side seals must be adjusted and in good condition.
Guide rollers	<ol style="list-style-type: none"> 1. Check the guide roller bearings. The guide roller bearings must be adjusted. 2. Check the front roller cams. The front roller cams must be adjusted. 3. Check the wear of the guide rollers [Refer to appendix <i>Measuring the wear of the guiding system, see on page 69</i>]. 4. Mount the drive unit on the first mast section on the base frame. 5. Check the adjustment of the drive unit with the first mast section. The drive unit must be adjusted to the mast.

NOTICE



The drive unit must be removed to inspect any of the components.

6.1.11 Cable management system

EN-AL-11-04-0034-01

Function / System	Operations
Cable bracket	<ol style="list-style-type: none"> 1. Check that the connections between the cable bracket and the drive unit are tight and in good condition. The connections between the cable bracket and the drive unit must be tight and in good condition.
Cable collect bin	<ol style="list-style-type: none"> 1. Check that the cable collect bin connections are tight and in good condition. The cable collect bin connections must be tight and in good condition. 2. Visually check the condition of the cable collect bin. The cable collect bin must not have dents or other damage that prevent the cable from coiling correctly. 3. Visually check the protector on the upper perimeter of the cable collect bin. The protector must not have significant damage or wear and must fully protect the upper perimeter of the cable collect bin, preventing contact of the cable with the upper edge of the bin. 4. Lubricate the cable collect bin [Refer to appendix Lubrication of the cable management system, see on page 70].
Trailing cable	<ol style="list-style-type: none"> 1. Visually check the condition of the trailing cable. The trailing cable must not have damage to the sheath, indentations, compression marks or marks caused by heat. 2. Lubricate the trailing cable [Refer to appendix Lubrication of the cable management system, see on page 70].
Cable guide	<ol style="list-style-type: none"> 1. Check that the cable guide connections are tight and in good condition. The cable guide connections must be tight and in good condition. 2. Visually check the condition of the cable guides. The rubber tabs of the cable guides must not have cracks or other damage.

6.1.12 Mast

EN-AL-11-04-0021-01

Function / System	Operations
Mast	<ol style="list-style-type: none"> 1. Visually check the condition of the mast sections. The mast sections must not have dents, cracks, corrosion or other damage. The mast sections must not have excessive wear in the areas where the connectors join the mast sections together. 2. Check the wear in the guide roller support areas on the mast [Refer to appendix Measuring the wear of the guiding system, see on page 69].
Mast connection system	<ol style="list-style-type: none"> 1. Check that the mast connection system is tight and in good condition. The mast connection system must be tight and in good condition. 2. Check the displacement of the mast connection system connectors. The mast connection system connectors are displaced when the fastening bolt is tightened and loosened.

6.1.13 Control boxes

EN-AL-11-04-0022-01

Function / System	Operations
Main control box	<ol style="list-style-type: none"> 1. Visually check the condition of the main control box. The main control box must not have dents, cracks, corrosion or other damage. 2. Open the main control box door. 3. Visually check the condition of the sealing and the door mechanism of the main control box. The sealing and the door mechanism of the main control box must be in good condition. 4. Visually check the condition of the components installed in the main control box. The components installed in the main control box (lights, connectors, warning buzzer, etc.) must be in good condition and installed correctly. 5. Close the main control box door. 6. Check that the bolts connecting the main control box to the drive unit are tight. The bolts must be tight.
Base frame control box	<ol style="list-style-type: none"> 1. Visually check the condition of the base frame control box. The base frame control box must not have dents, cracks, corrosion or other damage. The sealing of the base frame control box must be in good condition. 2. Visually check the condition of the components installed in the base frame control box. The components installed in the base frame control box (main switch and connectors) must be in good condition and installed correctly. 3. Check that the bolts connecting the base frame control box to the base frame are tight. The bolts must be tight.

6.1.14 Checking the overload system

EN-AL-11-04-0006-01

WARNING



The scaffolding transport system must be installed, anchored and have a minimum mast height of 2.5 m (base unit and first mast section) before carrying out any functional test.

Function / System	Operations
Overload adjustment	<ol style="list-style-type: none"> 1. Adjust the overload system following the overload adjustment instructions [Refer to appendix Adjusting the overload system, see on page 71].

6.1.15 Informative signs and documentation

EN-AL-11-04-0007-01

Function / System	Operations
Informative signs and documentation	<ol style="list-style-type: none"> 1. Visually check the condition of the documentation, signs and stickers supplied with the scaffolding transport system. The documentation, signs and stickers included with the scaffolding transport system should always be available, in good condition and legible.

6.1.16 Replacing the motor start-up capacitor

EN-AL-11-05-0001-01

WARNING



Electrical hazard. Before replacing the motor start-up capacitor, check that the service capacitor and the motor start-up capacitor are discharged. Otherwise, follow the discharge protocol.

Function / System	Operations
Start-up capacitor	<ol style="list-style-type: none"> 1. Turn the main switch on the base frame control box to the OFF position [Refer to section Base frame control box, see on page 17]. The scaffolding transport system ready light (green) should turn off. 2. Disassemble the motor junction box cover. 3. Replace the motor start-up capacitor. 4. Mount the motor junction box cover. 5. Turn the main switch on the base frame control box to the ON position. 6. Put a load of 300 kg into the box. 7. Press and hold the UP button, release it, and then press and hold the DOWN button. The scaffolding transport system should ascend and descend.

6.1.17 Overspeed safety device overhaul

EN-AL-11-05-0002-01

Function / System	Operations
Overspeed safety device overhaul	<ol style="list-style-type: none"> 1. Uncouple the box from the drive unit [Refer to section Installation of the box, see on page 31]. 2. Remove the mast drive unit from the base unit. 3. Disassemble the overspeed safety device. 4. Send the overspeed safety device to Alimak Manufacturing S.L. for it to be overhauled.

6.1.18 Replacing the overspeed safety device

EN-AL-11-06-0001-01

Function / System	Operations
Replacing the overspeed safety device	<ol style="list-style-type: none"> 1. Uncouple the box from the drive unit [Refer to section Installation of the box, see on page 31]. 2. Remove the mast drive unit from the base unit. 3. Disassemble the overspeed safety device. 4. Disassemble the overspeed safety device pinion. 5. Mount the pinion on the new overspeed safety device. 6. Mount the new overspeed safety device on the drive unit. 7. Insert the base unit mast drive unit.

6.1.19 Replacing the emergency top limit sensor

EN-AL-11-06-0002-01

Function / System	Operations
Emergency top limit sensor	<ol style="list-style-type: none"> 1. Turn the main switch on the base frame control box to the OFF position [Refer to section Base frame control box, see on page 17]. The scaffolding transport system ready light (green) should turn off. 2. Disassemble the bracket for the top limit sensors. 3. Disassemble the emergency top limit sensor connector. 4. Replace the emergency top limit sensor. 5. Mount the emergency top limit sensor connector. 6. Mount the bracket for the top limit sensors. 7. Adjust the emergency top limit sensor detection distance [Refer to section Emergency top limit sensor, see on page 18]. 8. Check and/or adjust the emergency top limit sensor [Refer to section Top limit sensor, see on page 18].

Appendix

Testing and adjusting the electromagnetic motor brake

EN-AL-12-04-0001-01

Checking and adjustment instructions

Stages	Operations
A1	<ol style="list-style-type: none"> 1. Turn the main switch on the base frame control box to the OFF position and lock it [Refer to section Base frame control box, see on page 17]. The scaffolding transport system ready light (green) should turn off. 2. Pull the electromagnetic motor brake release lever upwards to lower the scaffolding transport system until it touches the shock absorbers on the base frame. [Refer to section Drive system, see on page 13]. The scaffolding transport system should stop when it comes into contact with the shock absorbers on the base frame. 3. Disassemble the fan protection guard and then remove the fan. 4. Disassemble the electromagnetic brake protection guard. 5. Insert the feeler gauges at three different points 120° apart near the adjustment bolts to check the electromagnetic brake air gap [Refer to figure Electromagnetic brake air gap, see on page 42]. It should be possible to insert the 0.35 mm feeler gauge, but it should not be possible to insert the 0.6 mm feeler gauge. <ol style="list-style-type: none"> a. It should be possible to insert the 0.35 mm feeler gauge, but it should not be possible to insert the 0.6 mm feeler gauge. b. Otherwise, follow process A2 for the adjustment of the electromagnetic motor brake. 6. Mount the fan and the fan protection guard.
A2	<ol style="list-style-type: none"> 1. Disassemble the electromagnetic motor brake [Refer to figure Electromagnetic brake air gap, see on page 42]. 2. Disassemble the electromagnetic brake disc. 3. Check the electromagnetic brake disc. The electromagnetic brake disc has no corrosion, the wear is even, the friction material is well adhered to the metal core and there is no damage that could affect its functionality. 4. Check the electromagnetic brake disc thickness. The electromagnetic brake disc thickness must be more than 9 mm. 5. Mount the electromagnetic brake disc. 6. Mount the electromagnetic motor brake. 7. Adjust the electromagnetic brake using a 0.4 mm gauge. 8. Mount the fan and the fan protection guard.

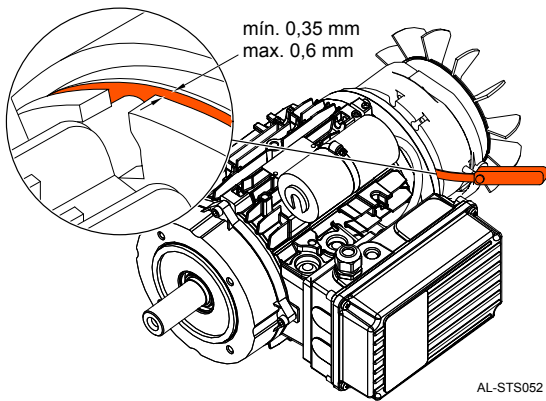

Figure 55 : Electromagnetic brake air gap

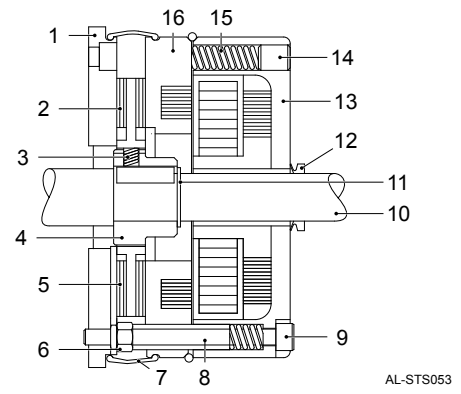

Figure 56 : Electromagnetic brake

Electromagnetic brake

- 1 Bearing plate
- 2 Friction flange
- 3 Anti-vibration O-ring
- 4 Driving hub
- 5 Brake disc
- 6 Locknut
- 7 Brake gasket
- 8 Guide column
- 9 Fastening bolt
- 10 Driving shaft
- 11 Seeger ring
- 12 "V" gasket
- 13 Brake coil
- 14 Brake torque adjustment bolt
- 15 Thrust spring
- 16 Mobile core

Measuring the wear of the rack and drive pinion

EN-AL-12-04-0002-01

Functions/ system	Operations
Drive pinion	<p>Measure the wear of the drive pinion with a calliper [Refer to figure <i>Measuring the wear of the drive pinion</i>, see on page 42] and repeat the measurement at three points on the drive pinion 120° apart.</p> <ol style="list-style-type: none"> The chordal distance between teeth must be less than 38.1 mm and more than 36.8 mm. Otherwise, replace the drive pinion and drive system counter rollers.
Rack	<p>Measure the wear of the rack with a roller calibrated at Ø8 and a calliper [Refer to figure <i>Measuring the wear of the rack</i>, see on page 42].</p> <ol style="list-style-type: none"> The distance between the rack base and the calibrated roller must be less than 29.9 mm and more than 28.2 mm. Otherwise, replace the rack.

NOTICE



The drive unit must be removed to inspect any of the components.

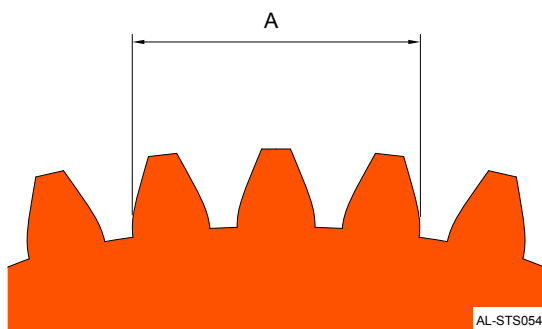

AL-ST5054

Figure 57 : Measuring the wear of the drive pinion

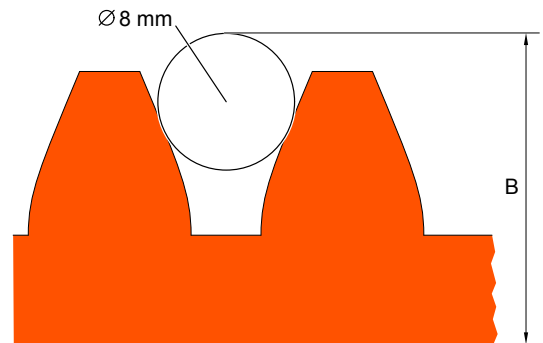

AL-ST5055

Figure 58 : Measuring the wear of the rack

Measuring the wear of the drive pinion

A | min. min. 36.8 mm/max. 38.1 mm

Measuring the wear of the rack

B | min. min. 28.2 mm/max. 29.9 mm

Checking the lubrication system

EN-AL-12-04-0003-01

Function / system	Operations
Automatic lubrication system	<ol style="list-style-type: none"> 1. Checking the lubricant specification [See appendix Lubricants, see on page 72]. The lubricant specification must be indicated by the manufacturer. 2. Check the lubricant level. The lubricant level must be more than ¼ of the maximum level. 3. Press and hold the SET button on the automatic lubrication system until the PU indication appears on the screen [Refer to figure Automatic lubrication system, see on page 42]. 4. Check that the lubrication system performs 3 lubricant discharges during approximately 25 sec. separated by intervals of 5 sec. <ol style="list-style-type: none"> a. If the lubricant is correctly discharged by the lubrication pinion, the lubrication system has no leaks. b. If the lubricant is not correctly discharged by the lubrication pinion or only a small amount of lubricant is discharged, check the lubrication system for leaks. c. If the cycle of 3 discharges is not completed, the lubrication system may be blocked or the lubricant may not be suitable. <p>Flush the lubrication system using a manual lubrication pump and/or replace the lubricant [Refer to appendix Lubricants, see on page 72].</p>
Manual lubrication system	<ol style="list-style-type: none"> 1. Check the lubricant level. The lubricant level must be more than ¼ of the maximum level. 2. Adjust the lubricant opening control between positions 1 and 3 depending on the ambient temperature. 3. Check that the lubrication system performs the lubricant discharge. <ol style="list-style-type: none"> a. If the lubricant is correctly discharged by the lubrication pinion, the lubrication system has no leaks. b. If the lubricant is not correctly discharged by the lubrication pinion or only a small amount of lubricant is discharged, check the lubrication system for leaks, obstructions and/or check that the lubricant is suitable [Refer to appendix Lubricants, see on page 72].
Replacing the lubricant cartridge	<ol style="list-style-type: none"> 1. Check the lubricant level and the lubrication system screen. The lubricant level is minimal or the lubricant cartridge is empty. The screen shows the LC indication and the red LED should flash [Refer to figure A1, see on page 68]. 2. Replace the lubricant cartridge. <ol style="list-style-type: none"> a. Disconnect the lubrication system cable [Refer to figure A1, see on page 68]. b. Disconnect the lubrication system from the lubrication point [Refer to figure A2, see on page 42]. c. Disconnect the lubricant cartridge from the lubrication system control unit [Refer to figure A3, see on page 42]. d. Connect the new lubricant cartridge of the lubrication system control unit [Refer to figure A4, see on page 42]. e. Connect the lubrication system to the lubrication point [Refer to figure A5, see on page 68]. f. Connect the lubrication system cable [Refer to figure A6, see on page 68]. 3. The lubrication system is operational again. The last active settings are applied to the lubrication system [Refer to figure A7, see on page 68].

NOTICE



The drive unit must be removed to inspect any of the components.

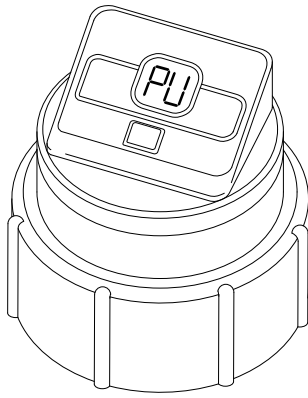

AL-STS056

Figure 59 : Automatic lubrication system

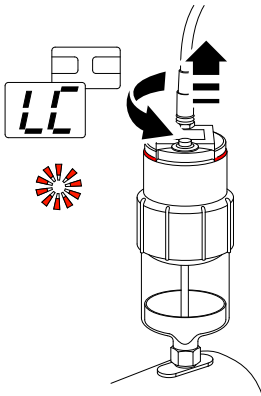

AL-STS069

Figure 60 : A1

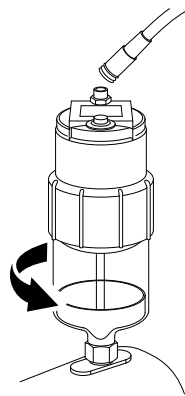

AL-STS070

Figure 61 : A2

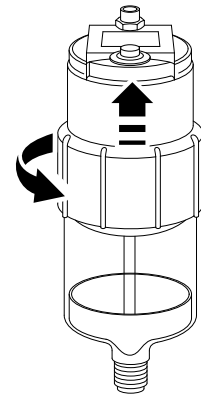

AL-STS071

Figure 62 : A3

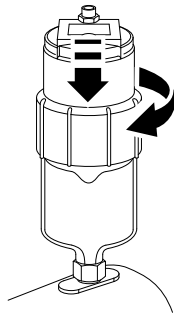

AL-STS072

Figure 63 : A4

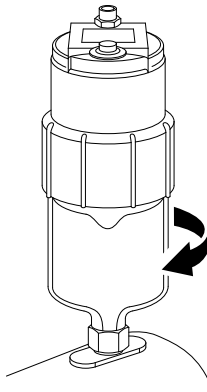

AL-STS073

Figure 64 : A5

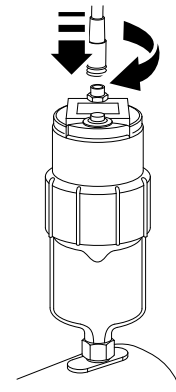

AL-STS074

Figure 65 : A6

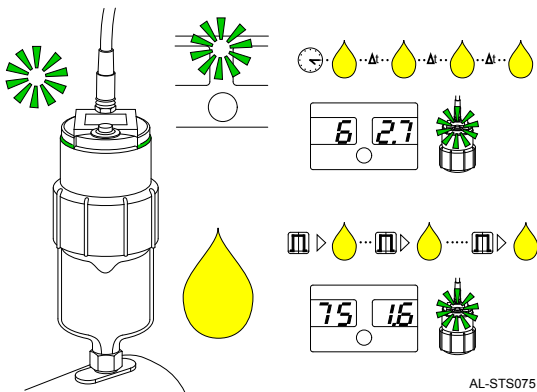

AL-STS075

Figure 66 : A7

Measuring the wear of the guiding system

EN-AL-12-04-0004-01

Function / system	Operations
Front rollers	<ol style="list-style-type: none"> Visually check the front rollers. The front rollers must be evenly worn and undamaged. Measure the wear of the front rollers using a calliper. <ol style="list-style-type: none"> The outer diameter of the front rollers must be less than 70 mm and more than 68 mm. Otherwise, replace the front rollers.
Secondary front rollers	<ol style="list-style-type: none"> Visually check the secondary front rollers. The secondary front rollers must be evenly worn and undamaged. Measure the wear of the secondary front rollers using a calliper. <ol style="list-style-type: none"> The outer diameter of the secondary front rollers must be less than 40 mm and more than 38 mm. Otherwise, replace the secondary front rollers.
Side rollers	<ol style="list-style-type: none"> Visually check the side rollers. The side rollers must be evenly worn and undamaged. Measure the wear of the side rollers using a calliper. <ol style="list-style-type: none"> The outer diameter of the side rollers must be less than 50 mm and more than 49 mm. Otherwise, replace the side rollers.
Mast guide	<ol style="list-style-type: none"> Visually check the mast guide. The mast guide must be evenly worn and must not be damaged. Measure the wear of the front roller guide using a calliper. <ol style="list-style-type: none"> The width of the front roller guide must be less than 84.5 mm and more than 82.5 mm [Refer to figure Mast guide, see on page 42]. Otherwise, the mast must be replaced. Measure the wear of the side roller guide using a calliper. <ol style="list-style-type: none"> The width of the side roller guide must be less than 88 mm and more than 87 mm [Refer to figure Mast guide, see on page 42]. Otherwise, the mast must be replaced.

NOTICE



The drive unit must be removed to inspect any of the components.

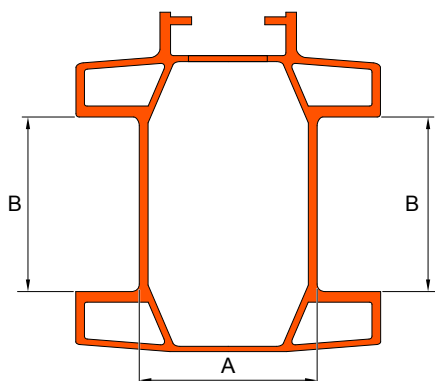

AL-ST5057

Figure 67 : Mast guide

Mast guide

A	min. min. 87 mm/max. 88 mm
B	min. min. 84.5 mm/max. 86.5 mm

Lubrication of the cable management system

EN-AL-12-04-0005-01

CAUTION



Risk of accident. Only apply lubricant to the trailing cable from a safe position and with the scaffolding transport system moving upwards.

Function / system	Operations
Cable bracket	Apply lubricant to the cable bracket's contact area with the cable guide [Refer to figure <i>Lubrication of the cable management system</i> , see on page 42 and the appendix <i>Lubricants</i> , see on page 72].
Cable collect bin	Apply lubricant to the inner wall of the cable collect bin [Refer to figure <i>Lubrication of the cable management system</i> , see on page 42 and the appendix <i>Lubricants</i> , see on page 72].
Trailing cable	Apply lubricant to the trailing cable [Refer to figure <i>Lubrication of the cable management system</i> , see on page 42 and the appendix <i>Lubricants</i> , see on page 72].

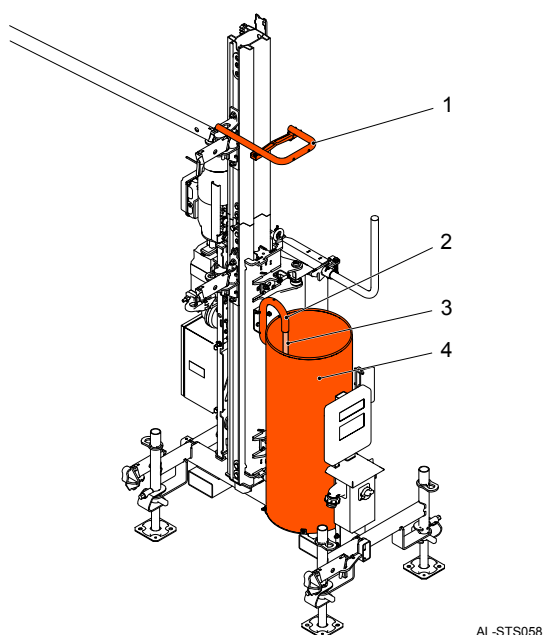

AL-ST5058

Figure 68 : Lubrication of the cable management system

Lubrication of the cable management system

- 1 Cable guide
- 2 Cable bracket
- 3 Trailing cable
- 4 Cable collect bin

Adjusting the overload system

EN-AL-12-05-0001-01

Function / system	Operations
Overload system	<ol style="list-style-type: none">1. Uncouple the box from the drive unit [Refer to section Installation of the box, see on page 31].2. Open the main control box door.3. Adjust the overload control unit [Refer to figure Overload control unit, see on page 71].<ol style="list-style-type: none">a. Programme Alarm 1 with a value of 60.b. Programme Alarm 2 with a value of 360.4. Close the main control box door.5. Check that the overload system is working correctly [Refer to section Checking the overload system, see on page 62].

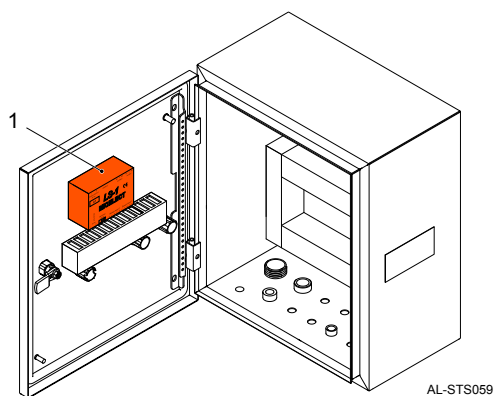

Figure 69 : Overload control unit

Overload control unit

- 1 | Main control box
- 2 | Overload control unit

Lubricants

EN-AL-12-03-0001-01

Function / system		Reference
Rack	Automatic lubrication system	Alicog Part No. 3001 396-108
	Manual lubrication system	Alicog Part No. 3001 396-108
Cable management system		Ali-low-fric compound Part No. 9052 045-000
Gearbox		Synthetic lubricant (ISO VG 220 -25°/+80°C) Recommended: Shell (Omala S4)

NOTICE



Do not use lubricants other than those specified without the verification and prior authorisation of Alimak.

Inspection prior to use checklist

EN-AL-12-06-0001-01

Installation information			
Date:		Serial no. of the scaffolding transport system:	
Name of the users:		Serial no. of the drive system:	
Hour counter reading:		Serial no. of the overspeed safety device:	
Installation address:			

Inspection prior to use checklist			
5.8.1 General	OK	NOK	Incidents and comments
Base unit			
Installation components			
Travel path			
5.8.2.1 Scaffolding transport system control	OK	NOK	Incidents and comments
Main switch			
Emergency-stop button			
Bottom limit switch			
Top limit sensor			
Overspeed safety device			

Result of inspection prior to use	OK	NOK	Incidents and comments
The scaffolding transport system is suitable for use			

Name of the certified user (in capital letters):	
Signature:	

NOTICE



Write the result of the verification in the OK or NOK field:

OK: result of the verification approved

NOK: result of the verification not approved

Installation and maintenance checklist

EN-AL-12-06-0002-01

Installation information			
Date:		Serial no. of the scaffolding transport system:	
Name of the certified technician:		Serial no. of the drive system:	
Hour counter reading:		Serial no. of the overspeed safety device:	
Installation address:			

Installation and maintenance checklist			
6.1.1 General	OK	NOK	Incidents and comments
Base unit			
Box			
Masts			
Anchor bracket/cable guide			
Trailing cable			
Travel path			
Lubrication system			
6.1.2 Control and safety devices	OK	NOK	Incidents and comments
Box detection switch			
Box fastening system switch			
Main switch			
Emergency-stop button			
2 m zone switch			
Bottom limit switch			
Top limit sensor			
Turning system switch			
Level sensor			
6.1.3 Overspeed safety device test	OK	NOK	Incidents and comments
Overspeed safety device test			
6.1.4 Emergency limit switch and sensor	OK	NOK	Incidents and comments
Emergency bottom limit switch			
Emergency top limit sensor			
6.1.5 Drive system	OK	NOK	Incidents and comments
Motor-gearbox and gearbox drive unit connections			
Seals			
Gearbox			
Motor junction box			
Electromagnetic brake			
6.1.6 Rack and pinion	OK	NOK	Incidents and comments
Drive pinion			
Rack			

NOTICE



Write the result of the verification in the OK or NOK field:

OK: result of the verification approved

NOK: result of the verification not approved

Installation and maintenance checklist			
6.1.7 Lubrication system	OK	NOK	Incidents and comments
Lubrication system			
6.1.8 Turning system	OK	NOK	Incidents and comments
Locking jaws			
Bearings			
Adjusting the height of the box anchoring system			
6.1.9 Box fastening system	OK	NOK	Incidents and comments
Box fastening system			
6.1.10 Guiding system	OK	NOK	Incidents and comments
Guiding system connections			
Drive system counter rollers			
Guide rollers			
6.1.11 Cable management system	OK	NOK	Incidents and comments
Cable bracket			
Cable collect bin			
Trailing cable			
Cable guide			
6.1.12 Mast	OK	NOK	Incidents and comments
Mast			
Mast connection system			
6.1.13 Control boxes	OK	NOK	Incidents and comments
Main control box			
Base frame control box			
6.1.14 Checking the overload system	OK	NOK	Incidents and comments
Overload adjustment			
6.1.15 Informative signs and documentation	OK	NOK	Incidents and comments
Informative signs and documentation			
6.1.16 Replacing the motor start-up capacitor	OK	NOK	Incidents and comments
Start-up capacitor			
6.1.17 Overspeed safety device overhaul	OK	NOK	Incidents and comments
Overspeed safety device overhaul			
6.1.18 Replacing the overspeed safety device	OK	NOK	Incidents and comments
Replacing the overspeed safety device			
6.1.19 Replacing the emergency top limit sensor	OK	NOK	Incidents and comments
Emergency top limit sensor			

Result of installation and maintenance inspection	OK	NOK	Incidents and comments
The scaffolding transport system is suitable for use			

Name of the certified technician (in capital letters):	
Signature:	

NOTICE



Write the result of the verification in the OK or NOK field:

OK: Result of the verification approved

NOK: Result of the verification not approved

Installation and maintenance log

EN-AL-12-01-0002-01

CAUTION



It is necessary to perform extraordinary inspections in case of loss of the Installation and Maintenance log.

Record the results of maintenance inspections and repairs performed on the scaffolding transport system on the Installation and maintenance log.

The Installation and Maintenance log must be available to the competent authority.

If necessary, request additional pages for the Installation and maintenance log from the manufacturer. Contact Alimak for assistance.

Date and time	Type of inspection	General result		Hour counter	Incidents and comments	Name (in capitals)	Signature
		OK	NOK				

NOTICE



Write the type of inspection performed on the scaffolding transport system in the Type of inspection field:

P: planned

R: repair

NOTICE



Write the result of maintenance inspections and repairs performed on the scaffolding transport system in the OK or NOK field:

OK: result of maintenance inspections and repairs performed on the scaffolding transport system approved

NOK: result of maintenance inspections and repairs performed on the scaffolding transport system not approved

Change log

EN-AL-02-00-0001-01

Revision	Date [month/year]	Description
01.01	03/2021	STS 300 scaffolding transport system (certification manual)
01.02	06/2021	Sections 1.4, 2.1, 2.4, 2.5, 2.6, 3.2, 3.4, 3.5, 5.2, 5.3, 5.4, 5.6, 5.8, 5.11, 5.13, 6.1 and Appendix updated Terminology updated
01.03	09/2021	Sections 2.4, 2.6, 3.1, 3.2, 3.3, 3.4, 3.5, 3.6, 5.1, 5.3, 5.4, 5.5, 5.11, 5.13, 6.1 and Appendix updated Terminology updated

ALIMAK

<https://my.alimak.com>

